

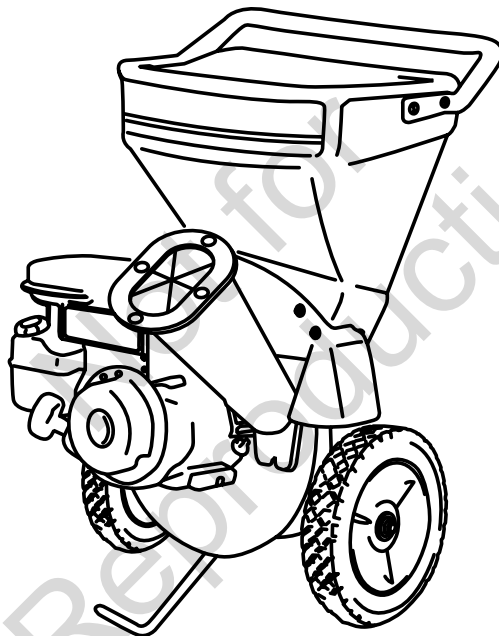

# **OPERATING INSTRUCTIONS**

## **1695924 CHIPPER/SHREDDER**



**Model 1695924**  
**Briggs and Stratton**  
**305cc**

Not for  
Reproduction

# Table of Contents

<b>Safety Rules &amp; Information.....</b>	<b>4</b>
Safety Decals .....	8
Safety Icons .....	8
Identification Numbers .....	10
<b>Initial Assembly .....</b>	<b>11</b>
Initial Assembly .....	11
<b>Features &amp; Controls .....</b>	<b>14</b>
Control Functions .....	14
<b>Operation.....</b>	<b>15</b>
General Operating Safety .....	15
Adding Fuel.....	15
Starting the Engine .....	15
Stopping the Engine.....	16
Processing Materials.....	16
Chipping / Shredding Recommendations .....	17
Storage.....	17
<b>Regular Maintenance .....</b>	<b>18</b>
Maintenance Schedule & Procedures.....	18
Check for Loose Hardware.....	18
Check Safety Labels .....	18
Inspect Cone, Hopper, & Guards .....	18
Clean Debris from Engine & Chipper.....	19
Inspect / Rotate Shredding Hammers.....	19
Inspect Chipping Knives.....	20
Check / Change Engine Air Cleaner.....	20
Replace Spark Plug .....	20
Engine Oil Type and Capacity .....	21
Check Engine Oil Level.....	21
Change Engine Oil.....	21
<b>Troubleshooting &amp; Repair.....</b>	<b>22</b>
Troubleshooting Chart.....	22
Repair .....	23
<b>Specifications .....</b>	<b>25</b>
<b>Warranty .....</b>	<b>26-27</b>

**NOTE:** In this manual, “left” and “right” are referred to as seen from the operating position.

# Safety Rules & Information



## Operating Safety

Congratulations on purchasing a superior-quality piece of lawn and garden equipment. Our products are designed and manufactured to meet or exceed all industry standards for safety.

Power equipment is only as safe as the operator. If it is misused, or not properly maintained, it can be dangerous! Remember, you are responsible for your safety and that of those around you.

Use common sense, and think through what you are doing. If you are not sure that the task you are about to perform can be safely done with the equipment you have chosen, ask a professional: contact your local authorized dealer.

## Read the Manual

The operator's manual contains important safety information you need to be aware of **BEFORE** you operate your unit as well as **DURING** operation.

Safe operating techniques, an explanation of the product's features and controls, and maintenance information is included to help you get the most out of your equipment investment.

Be sure to completely read the Safety Rules and Information found on the following pages. Also completely read the Operation section.

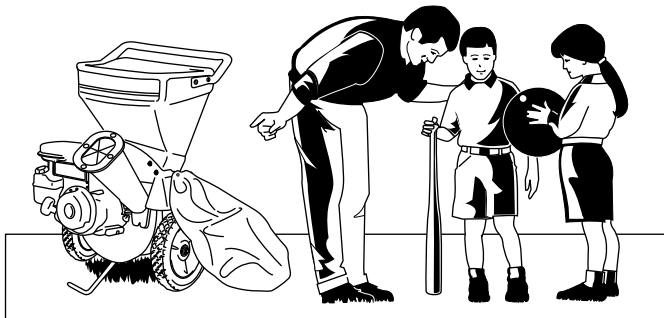

## Children

Tragic accidents can occur with children. Do not allow them anywhere near the area of operation. Children are often attracted to the unit and usage activity. Never assume that children will remain where you last saw them. If there is a risk that children may enter the area where you are operating, have another responsible adult watch them.

## Moving Parts

This equipment has many moving parts that can injure you or someone else. However, if you follow all the rules in this book, the unit is safe to operate.

The chipper/shredder has spinning blades that can amputate hands and feet. Do not allow anyone near the equipment while it is running! Do not place hands or feet in the hopper or chipper cone, or discharge chute.

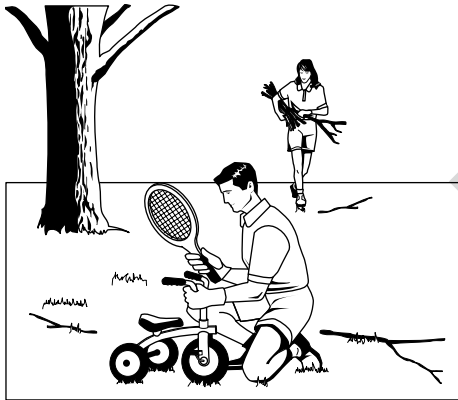
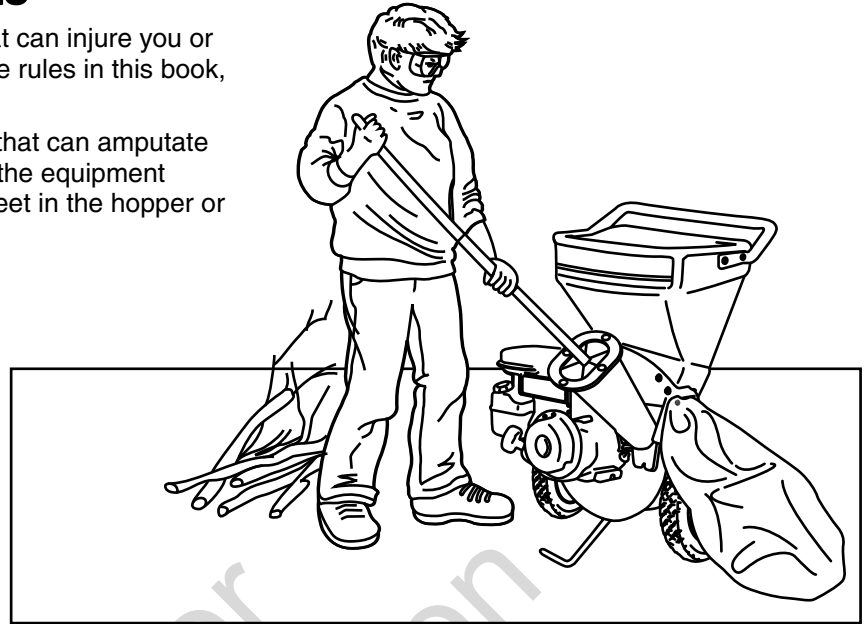

## Thrown Objects

This unit discharges debris at high speeds. Always wear protective goggles and do not operate without the debris bag in place. Also, do not allow anyone in the area while the unit is running! If someone does enter the area, shut the unit off immediately until they leave. Organize the work area prior to starting work.

## Fuel and Maintenance

Gasoline is extremely flammable. Its vapors are also extremely flammable and can travel to distant ignition sources. Gasoline must only be used as a fuel, not as a solvent or cleaner. It should never be stored any place where its vapors can build up or travel to an ignition source like a pilot light. Fuel belongs in an approved, plastic, sealed gas can, or in the fuel tank with the cap securely closed. Spilled fuel needs to be cleaned up immediately.

Proper maintenance is critical to the safety and performance of your unit. Be sure to perform the maintenance procedures listed in this manual, especially periodically testing the safety system.

## Safety Rules & Information



Read these safety rules and follow them closely. Failure to obey these rules could result in loss of control of unit, severe personal injury or death to you, or bystanders, or damage to property or equipment.

**This unit is capable of amputating hands and feet and throwing objects.** The triangle  in text signifies important cautions or warnings which must be followed.

### PREPARATION

1. Do not operate the equipment without wearing adequate outer garments and safety goggles. Avoid loose-fitting clothes and use protective footwear that will improve footing on slippery surfaces.

### TRAINING

1. Read the operating and service instructions carefully. Be thoroughly familiar with the controls and the proper use of the equipment. Know how to stop the unit and disengage the control quickly.
2. Keep the area of operation clear of all persons, particularly small children, and pets.

### GENERAL OPERATION

1. Read, understand, and follow all instructions in the manual and on the unit before starting.
2. Do not put hands or feet near rotating parts or under the machine. Keep clear of the discharge opening at all times.
3. Only allow responsible adults, who are familiar with the instructions, to operate the unit (local regulations can restrict operator age).
4. Be sure the area is clear of other people before operating. Stop the unit if anyone enters the area.
5. Never direct discharge material toward anyone. Avoid discharging material against a wall or obstruction. Material may ricochet back toward the operator.
6. Operate the machine only in daylight or good artificial light.
7. Do not operate the unit while under the influence of alcohol or drugs.
8. Always wear eye and hearing protection when operating this unit.
9. Keep in mind the operator is responsible for accidents occurring to other people or property.
10. It is a violation of California Public Resource Code Section 4442 to use or operate the engine on or near any forest-covered, brush-covered, or grass-covered land unless the exhaust system is equipped with a spark arrester meeting any applicable local or state laws. Other states or federal areas may have similar laws.
11. Always operate the chipper/shredder outdoors, on a firm, level, earthen or grassy surface where the unit will be stable and stay in position. Never attempt to operate the unit on a slope, or on a wet or slippery surface where you could slip and fall toward the chipper cone or hopper openings.
12. Never operate the chipper/shredder on asphalt, concrete, or other hard surfaces as material being ejected out of the discharge chute could ricochet, causing injury to you or bystanders.
13. Always obey the size limitations for tree limbs and branches stated in the Waste Materials Guide portion of this manual.
14. Never leave the machine running unattended. Always turn off the engine, wait for the rotor to come to a complete stop, and disconnect the spark plug before leaving the area. Always move the unit to a safe storage area when not in use.
15. Always maintain secure footing and solid balance while starting or operating the chipper/shredder. Never lean directly over the machine.
16. Always stand to the side of the chipper cone when feeding tree limbs and branches into the unit, as tree limbs, branches, and harder woods may kick back while being chipped.
17. Always keep hands out of the chipper cone and shredder hopper when feeding materials. Never wrap fingers tightly around branches as you are feeding them into the unit, as a sudden inward surge could pull your hands and arms into the unit.
18. Never allow material to build up in the discharge area or shredding chamber, as this may cause new material being fed into the machine to kickback with sufficient force to injure you or other bystanders.
19. Never allow material to build up around the engine during chipper/shredder operation. This could result in a fire, or overheating of the engine.
20. Never attempt to reposition or move the chipper/shredder unit while it is running. Doing so could cause the machine to tip over, and reaching to steady the unit could result in accidental insertion of your hands into the chipper cone or shredder hopper areas.
21. Never continue to operate the machine if it starts making unusual noise or vibration. Shut the engine off immediately, allow the rotor to stop, disconnect the spark plug wire and secure the wire away from the spark plug. Inspect the unit for any signs of damage or foreign material in the chipping or shredding areas. Remove any solid material that may be preventing the unit from operating properly.
22. Never attempt to clear clogs from the chipper cone, shredder hopper or discharge chute while the unit is

running. Always shut the engine off, allow the rotor to come to a complete stop, and remove the spark plug wire from the spark plug before removing excess materials.

23. Never attempt to perform any maintenance, repairs, or attachment of accessories while the unit is running. Always shut the unit off, allow the rotor to come to a complete stop, and remove the spark plug wire from the spark plug before beginning these activities.
24. Always make sure that the shredding chamber, shredder hopper, and chipper cone are empty before starting the unit after it has been idle. Attempting to start the unit with material in these areas could cause the engine starting cord to stop suddenly, injuring your hand and fingers, or toppling the unit over. Vibration is generally a warning sign of trouble.
25. Before cleaning, repairing, or inspecting, shut off the engine and make certain that all moving parts have come to a complete stop. Disconnect the spark plug wire and secure the wire away from the spark plug to prevent accidental starting.
26. Do not operate the engine in a confined space where dangerous carbon monoxide fumes can collect.
27. Never operate the machine without proper guards, plates, or other safety protective devices in place.
28. Use only attachments and accessories approved of by the manufacturer of the machine.

### **TRANSPORTING AND STORAGE**

1. Always observe safe refueling and fuel handling practices when refueling the unit after transportation or storage.
2. Never store the unit (with fuel) in an enclosed poorly ventilated structure. Fuel vapors can travel to an ignition source (such as a furnace, water heater, etc.) and cause an explosion. Fuel vapor is also toxic to humans and animals.
3. Always use the hopper handle and built-in wheels to move the chipper/shredder. Never lift the unit using the fuel tank for support. If the unit must be lifted, always use at least two people, and always grip the unit securely using the front leg and hopper handle.
4. Always follow the engine manual instructions for storage preparations before storing the unit for both short and long term periods.
5. Always follow the engine manual instructions for proper start-up procedures when returning the unit to service.
6. Never store the unit or fuel container inside where there is an open flame or pilot light, such as in a water heater. Allow unit to cool before storing.

### **CHILDREN**

Tragic accidents can occur if the operator is not alert to the presence of children. Children are often attracted to the unit and the operating activity. Never assume that children will remain where you last saw them.

1. Keep children out of the work area and under the watchful care of another responsible adult.
2. Be alert and turn unit off if children enter the area.
3. Never allow children to operate the unit.

### **EMISSIONS**

1. Engine exhaust from this product contains chemicals known, in certain quantities, to cause cancer, birth defects, or other reproductive harm.
2. Look for the relevant Emissions Durability Period and Air Index information on the engine emissions label.

### **IGNITION SYSTEM**

1. This spark ignition system complies with Canadian ICES-002.

### **SERVICE AND MAINTENANCE**

#### **Safe Handling of Gasoline**

1. Extinguish all cigarettes, cigars, pipes, and other sources of ignition.
2. Use only approved gasoline containers.
3. Never remove the gas cap or add fuel with the engine running. Allow the engine to cool before refueling.
4. Never fuel the machine indoors.
5. Never store the machine or fuel container where there is an open flame, spark, or pilot light such as near a water heater or other appliance.
6. Never fill containers inside a vehicle or on a truck bed with a plastic bed liner. Always place containers on the ground away from your vehicle before filling.
7. Remove gas-powered equipment from the truck or trailer and refuel it on the ground. If this is not possible, then refuel such equipment on a trailer with a portable container, rather than from a gasoline dispenser nozzle.

**Safety Rules and Information**

**Safety Decals**

This unit has been designed and manufactured to provide you with the safety and reliability you would expect from an industry leader in outdoor power equipment manufacturing.

Although reading this manual and the safety instructions it contains will provide you with the necessary basic knowledge to operate this equipment safely and effectively, we have placed several safety labels on the unit to remind you of this important information while you are operating your unit.

All DANGER, WARNING, CAUTION and instructional messages on your unit should be carefully read and obeyed. Personal bodily injury can result when these instructions are not followed. The information is for your safety and it is important! The safety decals below are on your unit.

If any of these decals are lost or damaged, replace them at once. See your local dealer for replacements.

These labels are easily applied and will act as a constant visual reminder to you, and others who may use the equipment, to follow the safety instructions necessary for safe, effective operation.

**Decal - Operating Instructions, North American Models**



**Decal - Danger, Rotating Cutting Blades, North American Models**



**Decal - Danger, Rotating Cutting Blades, Warning, Debris, North American Models**

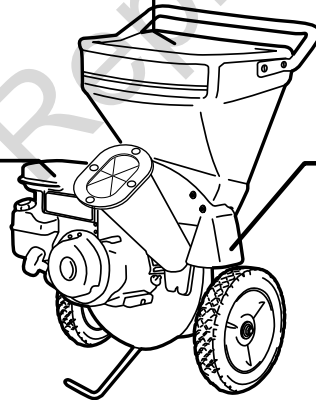



### Safety Icons (European Models)

**Warning: Read Operator's Manual.**

Read and understand the Operator's Manual before using this machine.



**Danger: Thrown Objects.**

This machine is capable of throwing objects and debris. Keep bystanders away.

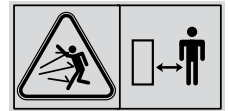

**Danger: Amputation Hazard.**

To avoid serious personal injury from rotating cutting blades, keep hands out of inlet while machine is running.



**Danger: Thrown Objects.**

This machine is capable of throwing objects and debris. Keep bystanders and children away when engine is running.

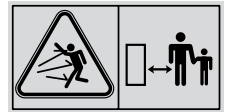

**Danger: Wear Appropriate Safety Equipment.**

This machine is capable of throwing objects and debris. Always wear safety goggles while operating.

This machine's operating sound power level is 109 dB(A) or more. Wear hearing protection while operating.



**Danger: Do Not Place Hands in the Machine.**

To avoid serious personal injury from rotating cutting blades, keep hands out of inlet while machine is running. Do not place hands in areas where this symbol is present.



**Warning: Disconnect the Spark Plug Wire Before Servicing.**

Disconnect the spark plug wire, and secure it away from the spark plug before servicing the unit.



Reproduction of this document is prohibited without the written permission of Simplicity Inc.

**Safety Rules and Information**

**Identification Numbers**

When contacting your authorized dealer for replacement parts, service, or information you **MUST** have these numbers.

Record your model name/number, manufacturer's identification numbers, and engine serial numbers in the space provided for easy access. These numbers can be found in the locations shown.

**NOTE:** For location of engine identification numbers, refer to the engine owner's manual.

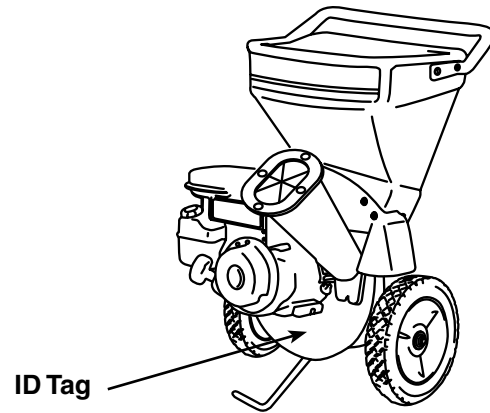

PRODUCT REFERENCE DATA	
Model Description Name/Number	
Unit PART Number	Unit SERIAL Number
Dealer Name	Date Purchased
ENGINE REFERENCE DATA	
Engine Make	Engine Model
Engine Type/Spec	Engine Code/Serial Number

Not for  
Reproduction

# Initial Assembly

## Initial Assembly

### Install Chipper Cone - All Models

1. Position the chipper cone (A) over the three 5/16-18 threaded studs protruding from the engine plate, and attach using three 5/16-18 flange nuts (B).
2. Rotate cone and cone base away from engine so cone does not contact engine.
3. Tighten the flange nuts securely.

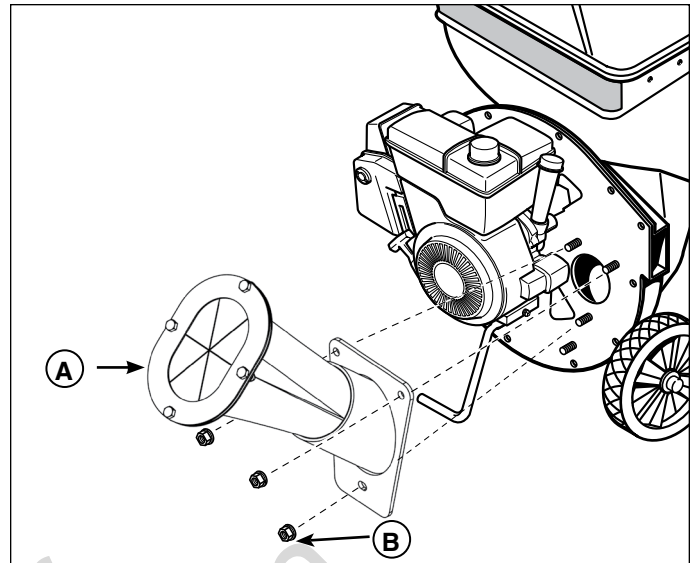

Figure 18. Installing the Chipper Cone  
A. Metal Cone Assembly  
B. 5/16-18 Flange Nut

Not for  
Reproduction

### Install the Hopper - All Models

1. Remove two 1/4 locknuts and flat washers from hopper liner and set aside. Attach the hopper to the rotor housing. Make sure to engage the metal lip of the hopper liner inside the housing.
2. Secure the hopper to the rotor housing using two 5/16 x 1/2 hex head bolts, two 5/16 flat washers and hardware removed from step 1 (Figure 19). Do not tighten hardware at this time.
3. See Figure 20. From the inside of the hopper install one 5/16-18 x 3/4 hex head bolt, 5/16 lockwasher, and 5/16 flat washer into each of the upper and lower holes of the metal hopper liner. Finger tighten only at this time.
4. Check that the hopper is seated correctly and tighten all hardware.

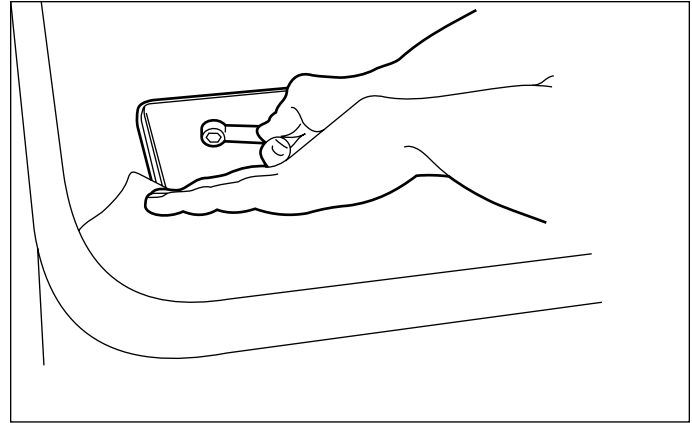

Figure 20. Installing Hardware Inside the Hopper

### Install the Handle - All Models

1. Lift the hopper handle up until the outer holes in the handle align with the holes in the shredder hopper and secure with 1/4-20 x 3/4 screws, washers, and nuts (A, Figure 21). Insert the screws from the outside of the shredder hopper.

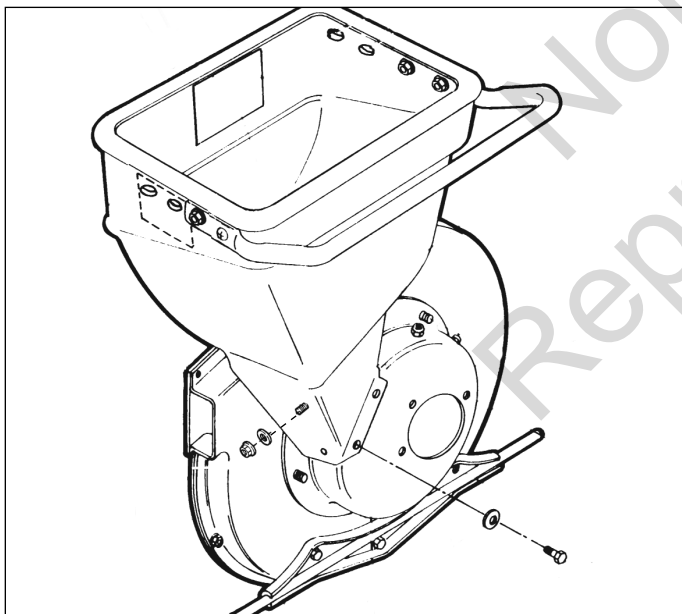

Figure 19. Attaching the Hopper

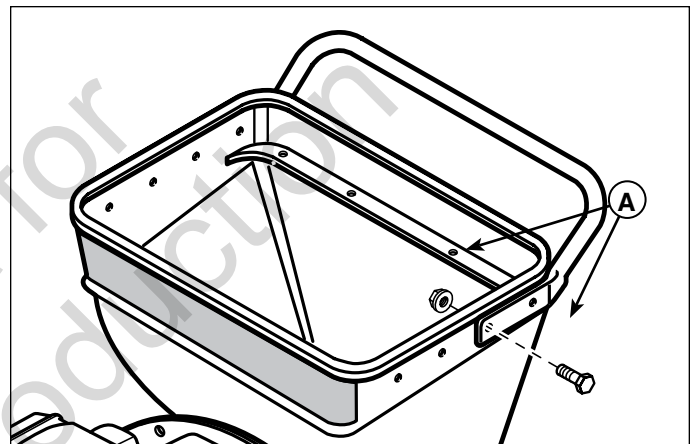
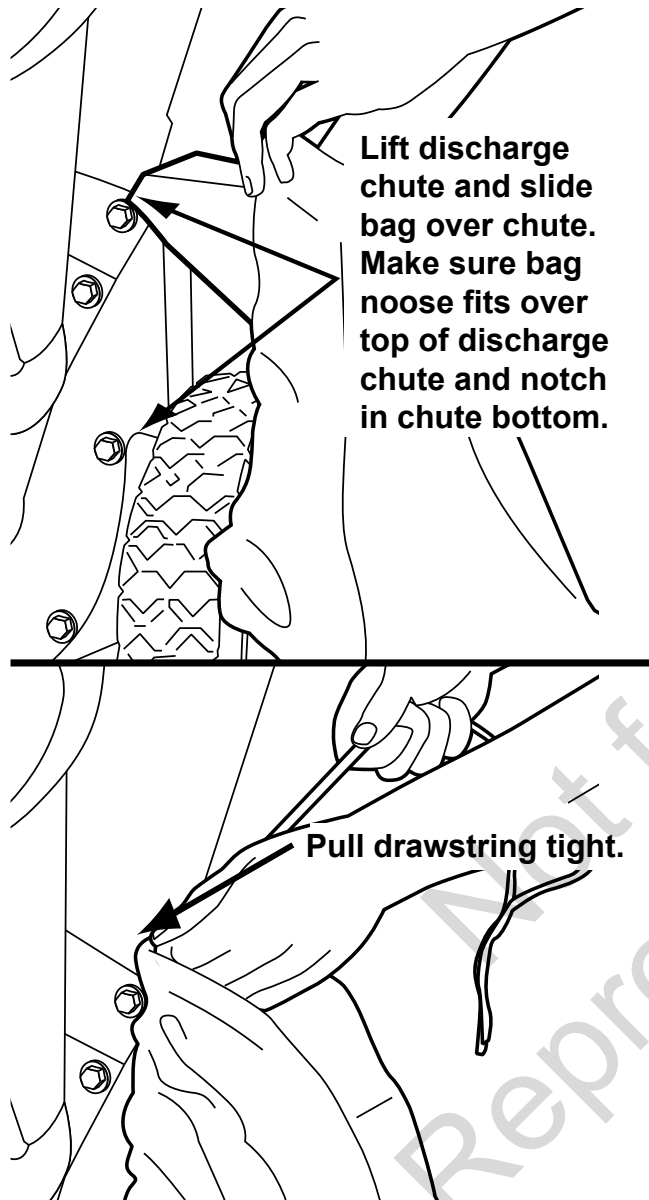

Figure 21. Installing the Hopper Handle  
A. 1/4-20 x 3/4 Screw & Nut



**Figure 22. Discharge Bag - North American Models**

**Install Discharge Bag**

This product comes with a discharge bag for collection of debris as it exits the discharge chute. Install the bag as shown in Figure 22 or 23.

**Add Engine Oil**

Refer to "Engine Oil Type and Capacity" in the Regular Maintenance section for oil type and fill procedures.

**Add Fuel**

Refer to "Adding Fuel" in the Operation section for fuel specifications and filling procedures.

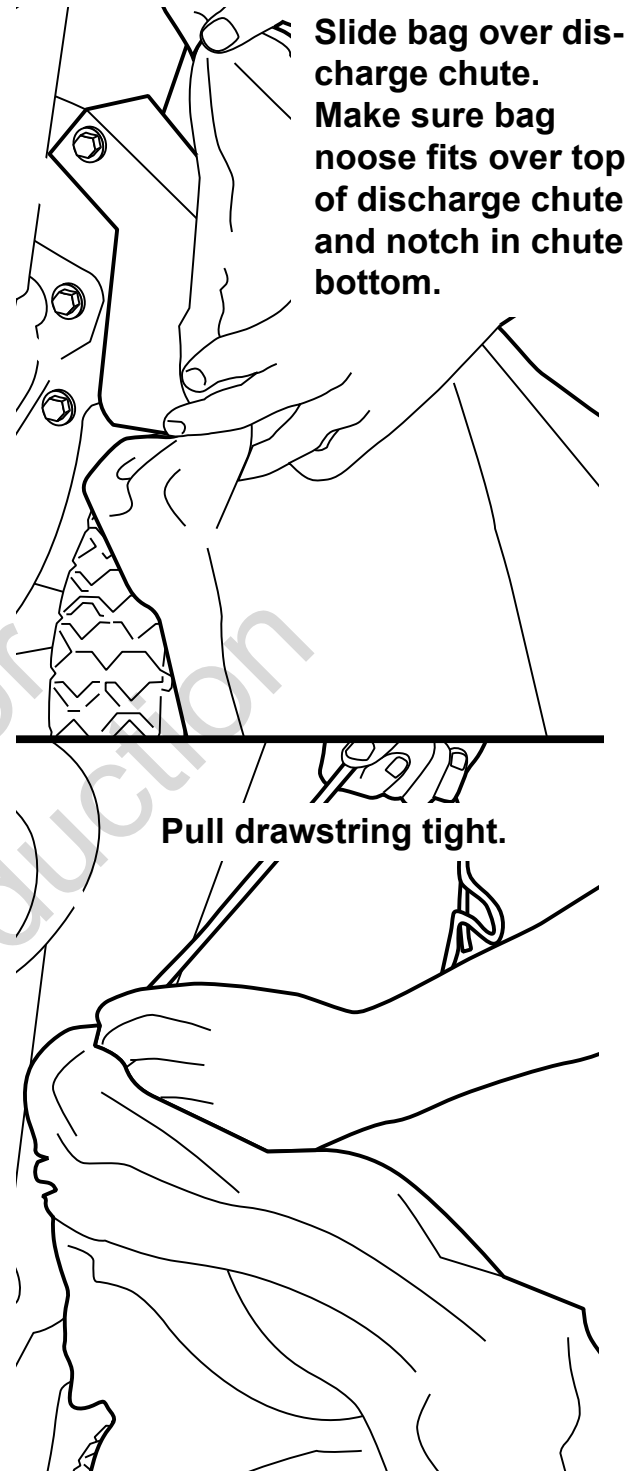

**Figure 23. Discharge Bag - CE Models**

# Features and Controls

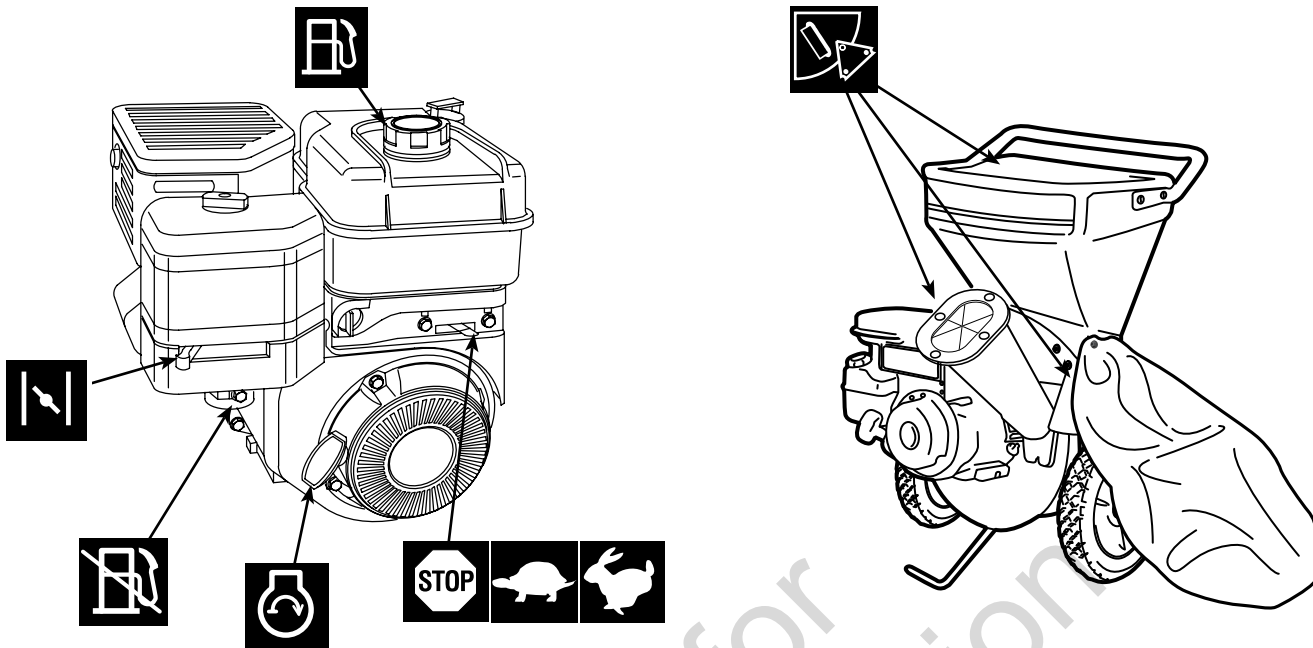

Figure 1. Controls

## Control Functions

The information below briefly describes the function of individual controls. Operating requires the combined use of several controls applied in specific sequences. To learn what combination and sequence of controls to use for various tasks see the OPERATION section.

### Engine Stop / Throttle Control

The engine stop / throttle control lever controls turn the engine off and controls the engine speed. Move the throttle right to increase engine speed and left to decrease engine speed. Moving the lever all the way to the left stops the engine. Always operate at FULL throttle (lever fully right).

### Recoil Starter

The recoil starter is used to turn the engine over for starting.

### Fuel Shut-Off Valve

The fuel shut-off valve is located below the air cleaner housing. Always close the valve when the unit is not in use.

### Choke

Close the choke for cold starting. Open the choke once

the engine starts. A warm engine may not require choking. Move the lever right to close the choke.

### Fuel Tank

To remove the cap, turn counterclockwise.

### Chipper Cone / Shredder Hopper

**Chipper Cone:** The chipper cone is located on the front of the unit next to the engine. Insert branches and tree limbs up to approximately 3" (7.6 cm) in diameter into the chipper cone. NEVER insert hands past the mouth of the cone.

**Shredder Hopper:** The shredder hopper is on top of the unit. Leaves and other light waste can be loaded into the shredder hopper. NEVER insert hands into the hopper.

**Debris Bag:** Use the debris bag to collect the material discharged from the unit. Do not operate the unit without the debris bag in place.

# Operation

## General Operating Safety

Be sure to read all information in the Safety and Operation sections before attempting to operate this unit. Become familiar with all of the controls and how to stop the unit.

Upon start-up and shut-down, you may hear the metal-to-metal sound of the triangular hammers and J-hammers positioning themselves on the rotor. This is normal. If this sound continues after the machine has reached full speed, contact your dealer for an inspection of the unit. Overloading the equipment will shorten its life, and can cause mechanical failures.

## Chipper Operation

The chipper is designed to handle tree limbs and branches up to approximately 3" (7,6 cm) in diameter. The chipping knives also permit the processing of course organic matter like corn stalks. Tree branches must be inserted large-end first into the chipper cone. Since occasional kick-backs may occur, always stand off to the side of the unit. Allow the self-feeding action of the unit to draw the sticks in.

## Shredder Operation

The shredder is designed to shred light brush, leaves, and other soft but bulky organic waste. As material is loaded into the shredder hopper it is pulled into the path of the triangular and J-hammers by air flow.

## Vacuum Attachment (Optional)

### WARNING

**To avoid serious personal injury from rotating cutting blades, keep hands out of inlet while machine is running.**

In addition to the chipper cone and hopper, loose debris may be processed by the Vacuum hose adapter kit. Leaves may be raked directly into the leaf tray where vacuum action will draw them into the shredder. For hard-to-reach areas, the nozzle and hose assembly may be used. The strength of the Vacuum may be changed using the rotating sleeve on the nozzle.

## Operating Location

Select an area with firm, level ground, covered by dirt or grass. Do not operate on wet or slick surfaces, or near bystanders. Locate and organize the materials to be processed so that you don't have to walk in front of the inlet or discharge openings, and so you have adequate room to work safely.

### DANGER

**The exhaust from this product contains carbon monoxide gas. Carbon monoxide is a colorless, orderless, and tasteless gas that can cause dizziness, nausea, unconsciousness, or even brain damage and death if inhaled for prolonged periods.**

**Operate the unit outdoors in a well ventilated location only. Keep children, pets, and bystanders away.**

**Failure to follow these instructions may result in serious injury or death.**

## Adding Fuel



Do not use gasoline containing METHANOL, gasohol containing more than 10% ETHANOL, gasoline additives, or white gas because engine/fuel system damage could result.

### WARNING

**Gasoline is highly flammable and must be handled with care. Never fill the tank when the engine is still hot from recent operation. Do not allow open flame, smoking or matches in the area. Avoid over-filling and wipe up any spills.**

To add fuel:

1. Remove the fuel cap (see Figure 1).
2. Fill the tank. Do not overfill. Leave room in the tank for fuel expansion. Refer to your engine manual for specific fuel recommendations.
3. Install and hand tighten the fuel cap.

## Starting the Engine

1. Set the throttle to FULL.
2. Close the choke.

**NOTE: A warm engine may not require choking.**

3. Place one foot on the front support leg to hold the unit firmly in place.
4. Pull the starting rope out to begin turning the engine over. Pull slowly at first and increase speed with each successive pull.
5. After the engine starts, open the choke and move the engine throttle control to SLOW. Warm up the engine

by running it for at least a minute.

6. Set throttle to FULL and begin chipping/shredding.

## Stopping the Engine

*NOTE: In the event of an emergency the engine can be stopped by setting the throttle control to STOP.*

1. Slide the throttle control fully left to the STOP position.

*NOTE: Upon start-up and shut-down, you may hear the metal-to-metal sound of the triangular hammers and J-hammers positioning themselves on the rotor. This is normal.*

2. After the engine has stopped moving, remove the spark plug wire and remove any debris from the unit and engine.

## Processing Materials

Most materials to be processed can be handled more efficiently by following these tips.

### Chipping Tips:

- Prune branches down close to the main branch to make feeding them into the chipper cone easier.
- Large, hard, dried tree branches that resist chipping can be processed by rotating them as you alternately insert and retract them.
- If the material to be chipped is extremely hard, kicks back forcefully when being fed into the chipper cone, or cannot be easily controlled, remove the material immediately and set it aside.
- If additional force is required to insert materials into the chipper, the blades probably need to be sharpened. Consult the Troubleshooting and Repair section of this manual, or see your authorized dealer.
- Maintain control of the materials you are feeding to prevent them from whipping around.
- Do not insert short pieces of material into the chipper cone by hand. Use a larger piece of material to force them into the chipper cone.

### Shredding Tips

- Don't overload the shredder by dumping large volumes of material into the hopper opening.
- Alternate loads of wet and dry material to prevent the discharge from becoming plugged.
- Never use any object to force material into the shredding hammers and damage the unit.



**Figure 2. Chipping.**



**Figure 3. Shredding.**



## Chipping & Shredding Recommendations

Operation	Type of Waste Permitted	Size Limitations	Notes
Shredding	Dry or moist organic material including leaves, plants, flowers, fruits, or vegetables.	Branches and twigs up to 1/2" diameter and 18" long.	Alternately chip or shred moist green waste with dry waste to avoid plugging of the discharge chute.  Process at a feeding rate that allows the rotor to keep up and maintain a high rate of speed.
Chipping	Long, thicker tree limbs or small bunches of smaller sticks grouped together for ease of handling.	Tree limbs and branches, or bundles of small sticks grouped for easier handling. Maximum diameter of approximately 3" (7,6 cm).	Bulky tree limbs should be pruned close to the main stem. Always use a shorter piece of wood to push end pieces into the chipper cone. Never place hands in the chipper cone.  Never chip very hard or dry materials such as kiln dried dimensional lumber (2x4's etc.) or other building materials.  Never use the chipper to process pressure-treated wood products.
Vacuum Attachment	Light, loose, dry waste such as leaves, grass clippings, or sawdust.	Small materials that will not obstruct the vacuum hose.	The vacuum is engineered for small, loose waste and for cleaning around decorative landscaping and flower beds. Twigs, wet leaves, and other bulky materials will clog the hose or obstruct the shredding chamber.

## Storage

Before you store your unit for the off-season, read the Maintenance and Storage instructions in the Safety Rules section, then perform the following steps:

- Perform engine maintenance and storage measures listed in the engine owner's manual. This includes draining the fuel system, or adding stabilizer to the fuel (do not store a fueled unit in an enclosed structure - see warning).

Before starting the unit after it has been stored:

- Check all fluid levels. Check all maintenance items.
- Perform all recommended checks and procedures found in the engine owner's manual.
- Allow the engine to warm up for several minutes before use.

# Regular Maintenance

## Maintenance Schedule & Procedures

The following schedule should be followed for normal care of your unit.

SAFETY ITEMS	Before Each Use	Every 5 Hours	Every 25 Hours	Every 100 Hours	Every 250 Hours	Spring & Fall
Check for loose hardware		•				•
Check all safety labels						•
Inspect cone, hopper, and guards.						•
CHIPPER MAINTENANCE ITEMS	Before Each Use	Every 5 Hours	Every 25 Hours	Every 100 Hours	Every 250 Hours	Spring & Fall
Clean debris from engine and chipper. **	•			•		
Inspect/Rotate Shredding Hammers			•			
Inspect/Rotate Chipping Knives			•			
ENGINE MAINTENANCE ITEMS	Before Each Use	Every 8 Hours	Every 25 Hours	Every 50 Hours	Every 100 Hours	Spring & Fall
Check Engine Oil Level *	•	•				
Change Engine Oil * **				•		
Check / Change Engine Air Filter * **			•			
Replace Spark Plug *					•	

\* Refer to engine owner's manual. Change original engine oil after initial break-in period of 5-8 hours.

\*\* More often in hot (over 85° F: 30° C) weather or dusty operating conditions.

### Check for Loose Hardware

**Service Interval: Every 5 hours; every spring and fall.**

Inspect the unit, checking for loose hardware or components. Pay special attention to the hardware attaching the chipper cone, hopper, axle, and front leg.

### Inspect Cone, Hopper, & Guards

**Service Interval: Every spring and fall.**

Check that the chipper cone, shredder hopper, and discharge guards are in place, undamaged, and secure. Replace any damaged or missing parts.

### Check Safety Labels

**Service Interval: Every spring and fall.**

Check that the safety labels are in place and undamaged. Sample illustrations and part numbers of the decals can be found on page 6. Replace any damaged or missing decals.

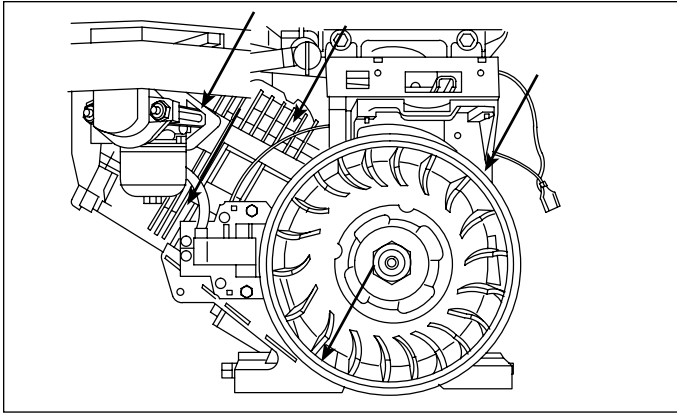
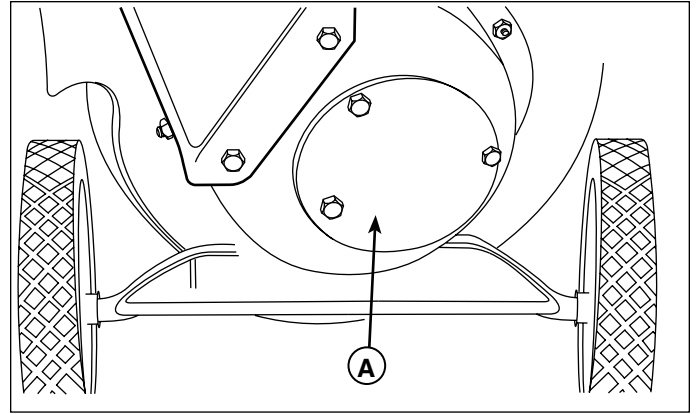
**Figure 4. Clean Debris from Engine Cooling Fins****Figure 5. Inspect Shredder Hammers  
A. Access Panel**

## Clean Debris from Engine & Chipper

**Service Interval: Before each use and every 100 hours.**

The engine requires air flow to cool itself and for combustion. Before each use, clean any debris from the unit especially from around the air shroud intake, air filter, and muffler. Every 100 hours, remove the engine air shroud and clean out any debris from the engine cooling fins at the locations shown in Figure 4. We recommend having this service performed by an authorized dealer.

## Inspect / Rotate Shredding Hammers

**Service Interval: Every 25 Hours, or As Necessary**

The shredding hammers of this unit can be rotated to provide a new cutting surface as required. The triangular hammers can be rotated twice, then flipped over for a total of 6 sharp cutting surfaces. The J-hammers can be flipped over once. To inspect the shredding hammers:

### **⚠ WARNING**

**Amputation hazard. To avoid serious injury from accidental starting, always disconnect the spark plug wire and secure it away from the spark plug when servicing the unit.**

1. Disconnect the spark plug wire and secure it away from the spark plug.
2. Remove the small circular access panel (A, Figure 5) from the back of the shredder housing.
3. Inspect the cutting edges of the triangular hammers (Figure 6) and J-hammers (Figure 7).

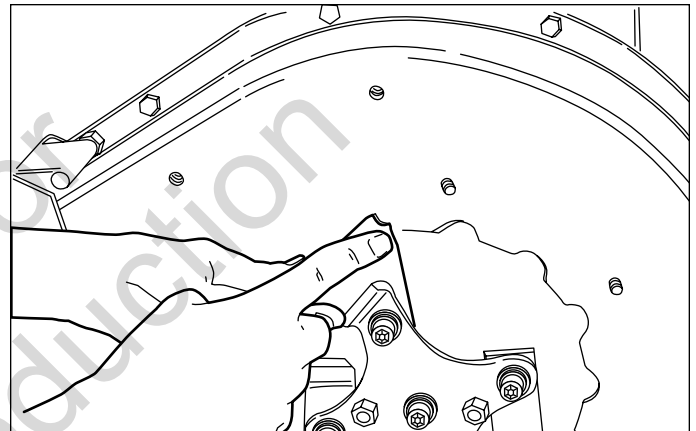
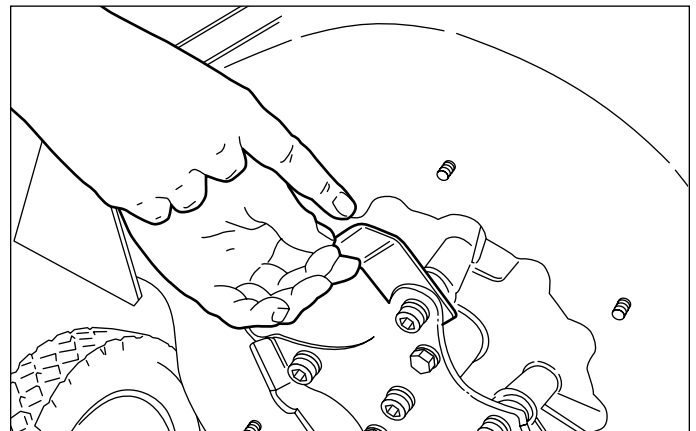
**Figure 6. Triangular Hammer Wear Area****Figure 7. J-Hammer Wear Area**

To rotate or replace the shredding hammers, see the Troubleshooting and Repair section.

## Inspect Chipping Knives

**Service Interval: Every 25 Hours, or As Necessary**

The chipping knives of this unit can be rotated or sharpened to provide a new cutting surface as required. When inspecting the knives be careful to avoid touching the sharpened edges. To inspect the chipping knives:

1. Disconnect the spark plug wire and secure it away from the spark plug.

### **! WARNING**

**To avoid serious injury from accidental starting, always disconnect the spark plug wire and secure it away from the spark plug when servicing the unit.**

2. See Figure 8. Remove the nuts securing the chipper cone to the front of the chipper. Remove the chipper cone (A) to access the knives.
3. Using the recoil starter, slowly pull the starter rope to rotate the rotor into position so the blades can be seen.

To sharpen or replace the chipper knives, see the Troubleshooting and Repair section.

## Check / Change Engine Air Cleaner

**Service Interval: Every 25 Hours**

The engine air cleaner assembly should be opened, inspected, and the filter element replaced every 25 hours, or as required if debris has built up in the assembly.

To replace the air filter and pre-cleaner assembly:

1. Loosen the screw (A, Figure 9) and remove the filter cover (B).
2. Inspect the pre-cleaner (C) and air filter element (D). If either are soiled, then replace.
3. Insert the new pre-cleaner (C) and air filter element (D) inside the filter cover (B). Make sure the arrows on the filter element are pointed up, and the lip of the pre-cleaner covers the bottom filter pleats.
4. Insert the cover tabs (F) into the filter base slots.
5. Tilt the cover up into place and tighten the screw (A).

## Replace Spark Plug

Please contact your authorized dealer to perform this service.

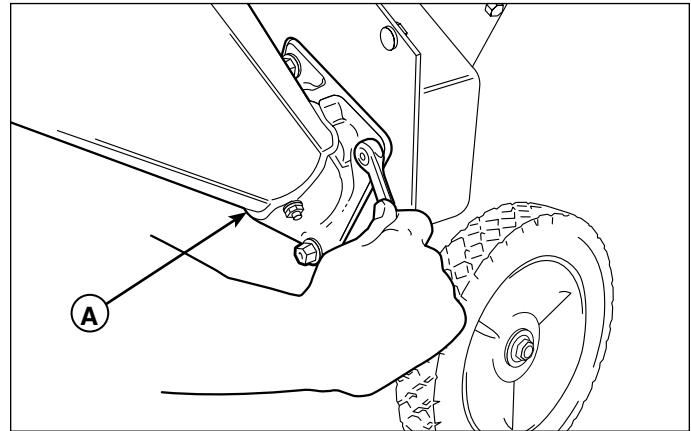

**Figure 8. Inspect Chipper Knives**  
**A. Chipper Cone**

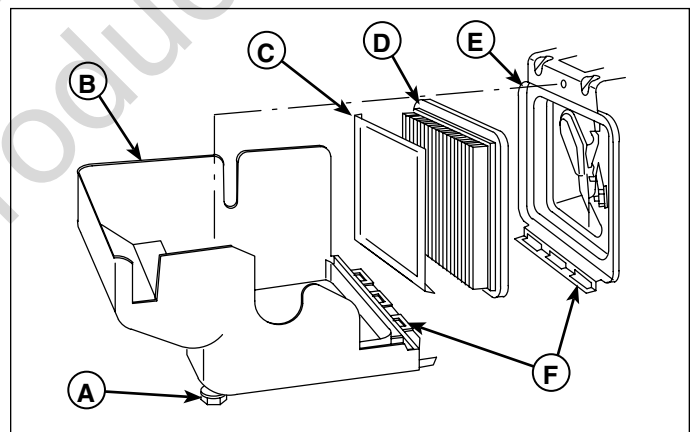

**Figure 9. Change Air Filter. NOTE: This illustration is for general reference only. Some engine models may appear different. Refer to the engine manual for more detailed instruction.**

- A. Screw**
- B. Filter Cover**
- C. Pre-Cleaner (Not included in some engine models)**
- D. Air Filter Element**
- E. Air Filter Base**
- F. Slots and Tabs**

### Engine Oil Type & Capacity

Select a quality engine oil using the chart in Figure 10. 8.5 torque rated models require 5/8 quart (0.6L) of oil.

### Check Engine Oil Level

**Service Interval: Before Each Use**

Check the engine oil level at the oil fill and level check plug (A, Figure 11).

1. Stop the engine and wait for all moving parts to stop.
2. Remove the oil fill and level check plug (A, Figure 11) by twisting it counter-clockwise. The oil should be filled up to the mouth of the filler opening as shown in the Figure 11 inset.

### Change Engine Oil

**Service Interval: Every 50 Hours**

1. Stop the engine and wait for all moving parts to stop. Allow the unit to cool before changing the oil.
2. Remove the oil fill and level check plug (A, Figure 11) by twisting it counter-clockwise.
3. Place an oil drain pan below the engine and remove the oil drain plug (B, Figure 11). Allow the oil to drain completely.
4. Reinstall the oil drain plug (B). Tighten the plug to 125 inch pounds (14 Nm)
5. Add oil to the oil fill hole (A) until the oil level is even with the bottom edge of the oil fill hole (Figure 11 inset).

### Use oil classified API Service Class SF, SG, SH, SJ or better with SAE Viscosity:

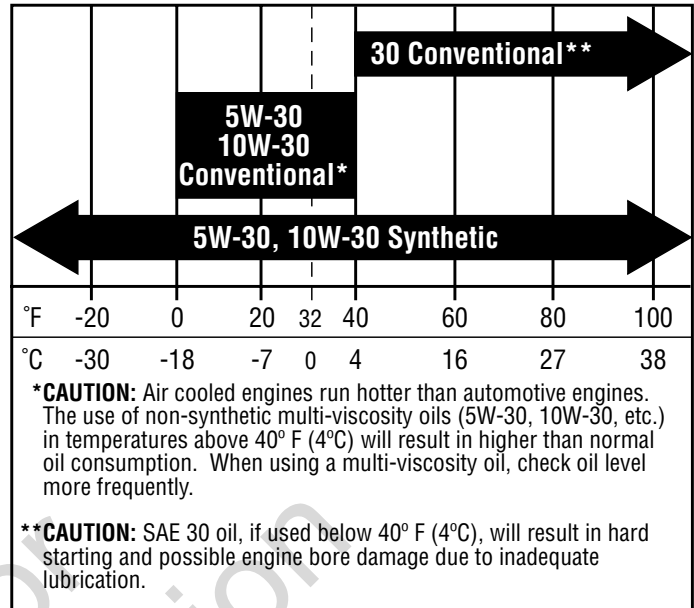

Figure 10. Oil Recommendations

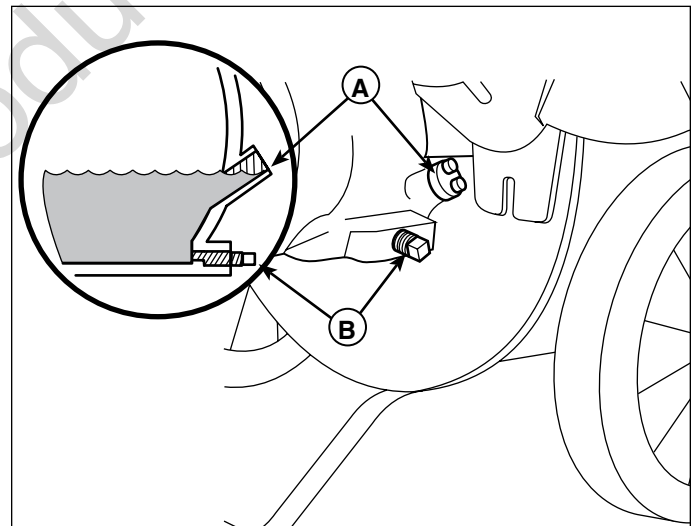

Figure 11. Oil Fill and Oil Drain

A. Oil Fill & Level Check Plug

B. Oil Drain Plug

# Troubleshooting & Repair

## Troubleshooting Chart

While normal care and regular maintenance will extend the life of your equipment, prolonged or constant use may eventually require that service be performed to allow it to continue operating properly.

The troubleshooting guide below lists the most common problems, their causes, and remedies.

See the information on the following pages for instructions on how to perform most of these minor adjustments and service repairs yourself. If you prefer, all of these procedures can be performed for you by your local authorized dealer.

## WARNING

**To avoid serious injury, perform maintenance on the unit only when the engine is stopped.**

**Always disconnect the spark plug wire and fasten it away from the plug before beginning the maintenance, to prevent accidental starting of the engine.**

PROBLEM	CAUSE	REMEDY
<b>Engine will not start.</b>	<ol style="list-style-type: none"> <li>1. Out of fuel.</li> <li>2. Spark plug wire disconnected.</li> <li>3. Engine controls not set correctly.</li> <li>4. Spark plug fouled.</li> <li>5. No compression. Recoil starter pulls with no resistance.</li> <li>6. No spark. Ignition problem.</li> <li>7. Old or stale fuel.</li> </ol>	<p>Add fuel.</p> <p>Reconnect spark plug wire.</p> <p>Refer to Starting in the Operation section.</p> <p>Remove the spark plug, clean or replace.</p> <p>See your authorized dealer.</p> <p>See your authorized dealer.</p> <p>See your authorized dealer.</p>
<b>Engine exhaust is black.</b>	<ol style="list-style-type: none"> <li>1. Dirty air filter.</li> <li>2. Choke closed.</li> </ol>	<p>Replace air filter. See engine manual.</p> <p>Open choke.</p>
<b>Engine runs but no material is discharged.</b>	<ol style="list-style-type: none"> <li>1. Discharge chute clogged.</li> <li>2. Engine not running at full speed.</li> </ol>	<p>Clean out debris.</p> <p>Set throttle control to FAST.</p>
<b>Excessive branch vibration when chipping materials.</b>	<ol style="list-style-type: none"> <li>1. Chipper knives dull.</li> <li>2. Tree limbs are extremely hard or dried out.</li> </ol>	<p>Sharpen or replace chipper knives.</p> <p>Material is not suitable for chipping.</p>
<b>Unusual noise or vibration when processing material.</b>	<ol style="list-style-type: none"> <li>1. Rotor overloaded with material.</li> <li>2. Hammers are broken, bent, or loose.</li> <li>3. Hammers frozen in place.</li> </ol>	<p>Allow unit to clear itself before adding more material to the hopper.</p> <p>Check assembly. Tighten or replace as required.</p> <p>Check for obstructions and debris. Repair as necessary.</p>
<b>Vacuum not working.</b>	<ol style="list-style-type: none"> <li>1. Hopper lid not in place.</li> <li>2. Material too wet.</li> <li>3. Hose not attached properly.</li> <li>4. Hose obstructed or damaged.</li> <li>5. Engine not running at full RPM.</li> </ol>	<p>Install lid.</p> <p>Allow material to dry.</p> <p>Attach hose per instructions (see hose kit).</p> <p>Clear blockage or replace.</p> <p>Set throttle control to FAST.</p>

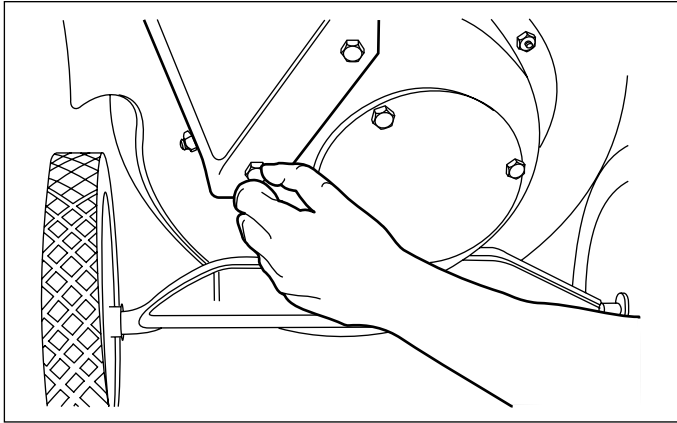

**Figure 12. Removing the Shredder Hopper**

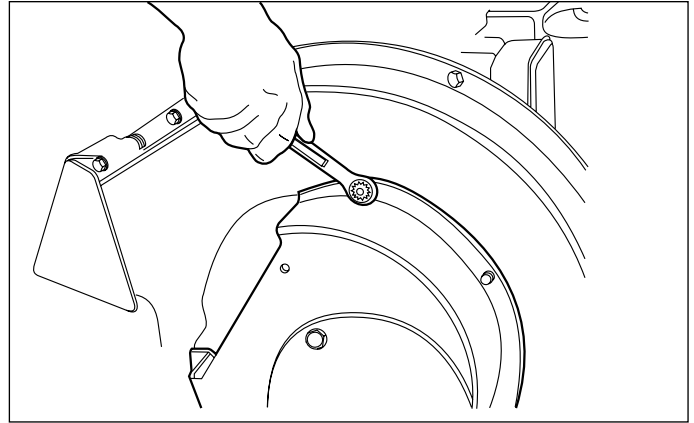

**Figure 13. Removing the Rotor Housing**

## Repair

### Shredding Hammer Rotation and Replacement

The cutting edges of the shredding hammers may eventually wear out requiring rotation of the hammer or replacement if all cutting edges have been dulled.

Triangular hammers can be rotated twice after the first edge dulls, then flipped over once and rotated again for a total of 6 edges. J-hammers can be flipped over once for a total of two cutting edges.

To rotate the shredding hammers:

1. Turn the engine off and wait for all moving parts to stop.
2. Disconnect the spark plug wire and secure it away from the spark plug.

### **⚠️ WARNING**

**To avoid serious injury from accidental starting, always disconnect the spark plug wire and secure it away from the spark plug when servicing the unit.**

3. Detach the shredder hopper from the rotor housing (Figure 12).
4. Remove the rotor cover by removing the hardware that secures it to the main housing (Figure 13).
5. Note the assembly sequence of the hardware used to secure the hammers (Figure 14). Using a 5/16" allen wrench remove the socket head capscrew (A) and related hardware.
6. Inspect the hammers (G, H), spacer tubes (D, F), and hardware. If the spacer tube (D, F) shows signs of wear, replace it. Inspect and flip, or replace the hammers (G, H).
7. Reassemble the hammers, spacers, washers, and

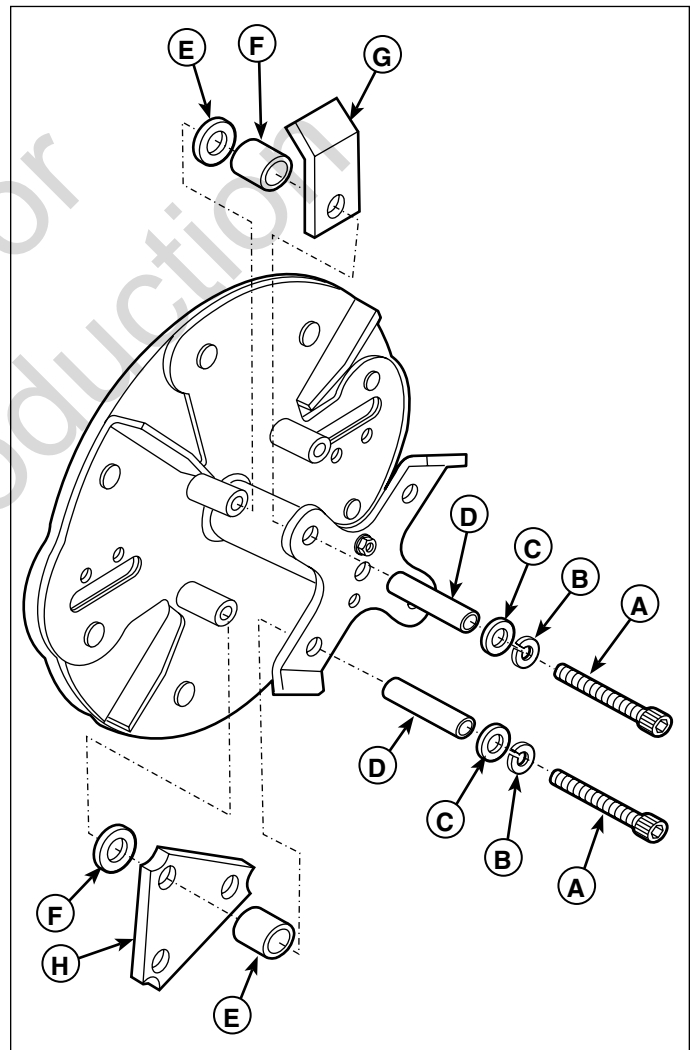

**Figure 14. Removing the Rotor Housing**

- |                               |                                  |
|-------------------------------|----------------------------------|
| <b>A. Socket Hd. Capscrew</b> | <b>E. Spacer, Short</b>          |
| <b>B. Lockwasher, 3/8</b>     | <b>F. Washer, 3/8 (8HP Only)</b> |
| <b>C. Washer, 7/8</b>         | <b>G. J-Hammer</b>               |
| <b>D. Spacer, Long</b>        | <b>H. Triangular Hammer</b>      |

capscrews. Torque the socket head capscrews (A) to 30-35 ft. lbs. (41-47 N.m.) Refer to Figure 14 for assembly. The J-hammer (G) on the opposite side of the rotor faces outward for balanced rotation.

Repeat for all the hammers.

### Chipping Knives Sharpening and Replacement

The chipping knives should be sharpened or replaced when tree limbs require extra force to feed into the chipper cone.

The chipping knives may be resharpened at a 30 degree angle until the distance between the edge of the blade bevel and the mounting hole is less than 1/16" (1.6mm) (see Figure 17).

### **! WARNING**

**Amputation hazard. To avoid serious injury from accidental starting, always disconnect the spark plug wire and secure it away from the spark plug when servicing the unit.**

To inspect, sharpen, or replace the chipping knives:

1. Turn the engine off and wait for all moving parts to stop.
2. Disconnect the spark plug wire and secure it away from the spark plug.
3. Detach the shredder hopper from the rotor housing (see Figure 12).
4. Remove the rotor cover by removing the hardware that secures it to the main housing (see Figure 13).

### **! WARNING**

**Cutting hazard. To avoid serious injury, avoid contacting the sharp cutting edges of the chipping knives.**

5. Remove the chipper cone base (Figure 15).
6. Rotate the rotor assembly so that the socket head capscrews that secure one of the chipper knives can be accessed through the rotor cover and access hole (Figure 16).
7. Using a 1/4" hex wrench, loosen and remove the two socket head capscrews and chipper knife.
8. Inspect, rotate, sharpen, or replace the chipper knife.
9. Reinstall the chipper knife and tighten the socket head capscrews to 18-20 ft. lbs (24-27 N.m.).
10. Rotate the rotor 180 degrees and repeat with the other chipper knife. Reinstall the rotor cover and shredder hopper when completed.

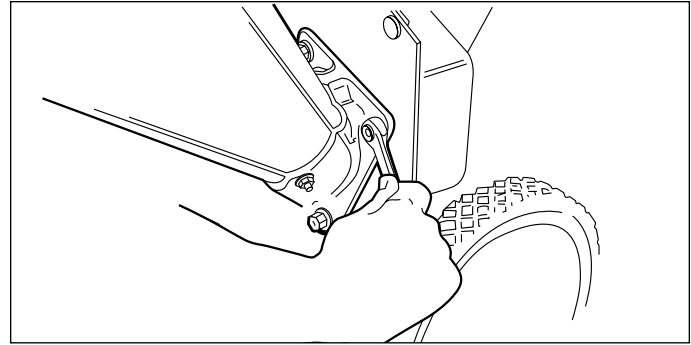

Figure 15. Installing the Chipper Cone

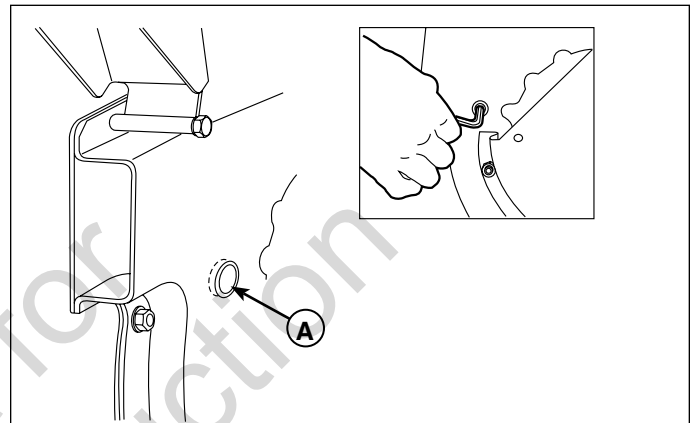

Figure 16. Access Hole  
A. Access Hole

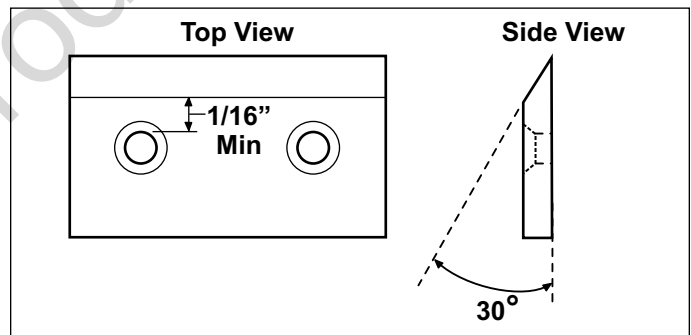

Figure 17. Chipper Knife Minimum Cutting Edge



# Specifications

---

**NOTE:** Specifications are correct at time of printing and are subject to change without notice.

\* Actual sustained equipment horsepower will likely be lower due to operating limitations and environmental factors.

## CHASSIS:

### All Models

<b>Chipping Capacity</b>	Approximately 3" (7.6 cm)
<b>Shredding Capacity</b>	1/2" x 18" Long
<b>Chipping Knives</b>	2
<b>Shredding Hammers</b>	2 J-hammers, 2 triangular hammers
<b>Waste Reduction Ratio</b>	Approximately 20:1
<b>Weight</b>	Model 1695924: 8.50 Torque Rating 130 lbs.

Not for  
Reproduction

**BRIGGS & STRATTON POWER PRODUCTS GROUP, L.L.C. OWNER WARRANTY POLICY**

**LIMITED WARRANTY**

Briggs & Stratton Power Products Group, LLC will repair and/or replace, free of charge, any part(s) of the equipment that is defective in material or workmanship or both. Briggs & Stratton Corporation will repair and/or replace, free of charge, any part(s) of the Briggs and Stratton engine\* (if equipped) that is defective in material or workmanship or both. Transportation charges on product submitted for repair or replacement under this warranty must be borne by purchaser. This warranty is effective for the time periods and subject to the conditions stated below. For warranty service, find the nearest Authorized Service Dealer using our dealer locator at [www.BriggsandStratton.com](http://www.BriggsandStratton.com) or [www.Murray.com](http://www.Murray.com).

There is no other express warranty. Implied warranties, including those of merchantability and fitness for a particular purpose, are limited to one year from purchase or to the extent permitted by law. Liability for incidental or consequential damages are excluded to the extent exclusion is permitted by law.

Some states or countries do not allow limitations on how long an implied warranty lasts, and some states or countries do not allow the exclusion or limitation of incidental or consequential damages, so the above limitation and exclusion may not apply to you. This warranty gives you specific legal rights and you may also have other rights which vary from state to state or country to country.

**WARRANTY PERIOD**

<u>Item</u>	<u>Consumer Use</u>	<u>Commercial Use:</u>
Equipment	2 Years	90 Days
Engine*	2 Years	90 Days
Battery	1 Year	1 Year

The warranty period begins on the date of purchase by the first retail consumer or commercial end user, and continues for the period of time stated above. "Consumer use" means personal residential household use by a retail consumer. "Commercial use" means all other uses, including use for commercial, income producing or rental purposes. Once product has experienced commercial use, it shall thereafter be considered as commercial use for purposes of this warranty.

No warranty registration is necessary to obtain warranty on Briggs & Stratton products. Save your proof of purchase receipt. If you do not provide proof of the initial purchase date at the time warranty service is requested, the manufacturing date of the product will be used to determine warranty eligibility.

**ABOUT YOUR WARRANTY**

We welcome warranty repair and apologize to you for being inconvenienced. Warranty service is available only through servicing dealers authorized by Briggs & Stratton or BSPPG, LLC.

Most warranty repairs are handled routinely, but sometimes requests for warranty service may not be appropriate. This warranty only covers defects in materials or workmanship. It does not cover damage caused by improper use or abuse, improper maintenance or repair, normal wear and tear, or stale or unapproved fuel.

**Improper Use and Abuse** - The proper, intended use of this product is described in the Operator's Manual. Using the product in a way not described in the Operator's Manual or using the product after it has been damaged will void your warranty. Warranty is not allowed if the serial number on the product has been removed or the product has been altered or modified in any way, or if the product has evidence of abuse such as impact damage, or water/chemical corrosion damage.

**Improper Maintenance or Repair** - This product must be maintained according to the procedures and schedules provided in the Operator's Manual, and serviced or repaired using genuine Briggs & Stratton parts. Damage caused by lack of maintenance or use of non-original parts is not covered by warranty.

**Normal Wear** - Like all mechanical devices, your unit is subject to wear even when properly maintained. This warranty does not cover repairs when normal use has exhausted the life of a part or the equipment. Maintenance and wear items such as filters, belts, cutting blades, and brake pads (engine brake pads are covered) are not covered by warranty due to wear characteristics alone, unless the cause is due to defects in material or workmanship.

**Stale Fuel** - In order to function correctly, this product requires fresh fuel that conforms to the criteria specified in the Operator's Manual. Damage caused by stale fuel (carburetor leaks, clogged fuel tubes, sticking valves, etc) is not covered by warranty.

\* Applies to Briggs and Stratton engines only. Warranty coverage of non-Briggs and Stratton engines is provided by the engine manufacturer.



California, U.S. EPA, and Briggs & Stratton Corporation Emissions Control Warranty Statement  
Your Warranty Rights And Obligations

April 2011

The California Air Resources Board, U.S. EPA, and Briggs & Stratton (B&S) are pleased to explain the emissions control system warranty on your Model Year 2011-2012 engine/equipment. In California, new small off-road engines and large spark ignited engines less than or equal to 1.0 liter must be designed, built, and equipped to meet the State's stringent anti-smog standards. B&S must warrant the emissions control system on your engine/equipment for the periods of time listed below provided there has been no abuse, neglect, or improper maintenance of your engine or equipment.

Your emissions control system may include parts such as the carburetor or fuel injection system, fuel tank, ignition system, and catalytic converter. Also included may be hoses, belts, connectors, sensors, and other emissions-related assemblies.

Where a warrantable condition exists, B&S will repair your engine/equipment at no cost to you including diagnosis, parts, and labor.

**Manufacturer's Warranty Coverage:**

Small off-road engines and large spark ignited engines less than or equal to 1.0 liter are warranted for two years. If any emissions-related part on your engine/equipment is defective, the part will be repaired or replaced by B&S.

**Owner's Warranty Responsibilities:**

- As the engine/equipment owner, you are responsible for the performance of the required maintenance listed in your owner's manual. B&S recommends that you retain all receipts covering maintenance on your engine/equipment, but B&S cannot deny warranty solely for the lack of receipts or your failure to ensure the performance of all scheduled maintenance.
- As the engine/equipment owner, you should however be aware that B&S may deny you warranty coverage if your engine/equipment or a part has failed due to abuse, neglect, improper maintenance, or unapproved modifications.
- You are responsible for presenting your engine/equipment to a B&S distribution center, servicing dealer, or other equivalent entity, as applicable, as soon as a problem exists. The warranty repairs should be completed in a reasonable amount of time, not to exceed 30 days. If you have any questions regarding your warranty rights and responsibilities, you should contact B&S at (414) 259-5262.

**Briggs & Stratton Emissions Control Warranty Provisions**

The following are specific provisions relative to your Emissions Control Warranty Coverage. It is in addition to the B&S engine warranty for non-regulated engines found in the Operator's Manual.

1. Warranted Emissions Parts

Coverage under this warranty extends only to the parts listed below (the emissions control systems parts) to the extent these parts were present on the B&S engine and/or B&S supplied fuel system.

- a. Fuel Metering System
  - Cold start enrichment system (soft choke)
  - Carburetor and internal parts
  - Fuel pump
  - Fuel line, fuel line fittings, clamps
  - Fuel tank, cap and tether
  - Carbon canister
- b. Air Induction System
  - Air cleaner
  - Intake manifold
  - Purge and vent line
- c. Ignition System
  - Spark plug(s)
  - Magneto ignition system
- d. Catalyst System
  - Catalytic converter
  - Exhaust manifold
  - Air injection system or pulse valve
- e. Miscellaneous Items Used in Above Systems
  - Vacuum, temperature, position, time sensitive valves and switches
  - Connectors and assemblies

2. Length of Coverage

For a period of two years from date of original purchase, B&S warrants to the original purchaser and each subsequent purchaser that the engine is designed, built, and equipped so as to conform with all applicable regulations adopted by the Air Resources Board; that it is free from defects in material and workmanship that could cause the failure of a warranted part; and that it is identical in all material respects to the engine described in the manufacturer's application for certification. The warranty period begins on the date the engine is originally purchased.

The warranty on emissions-related parts is as follows:

- Any warranted part that is not scheduled for replacement as required maintenance in the owner's manual supplied, is warranted for the warranty period stated above. If any such part fails during the period of warranty coverage, the part will be repaired or replaced by B&S at no charge to the owner. Any such part repaired or replaced under the warranty will be warranted for the remaining warranty period.
- Any warranted part that is scheduled only for regular inspection in the owner's manual supplied, is warranted for the warranty period stated above. Any such part repaired or replaced under warranty will be warranted for the remaining warranty period.
- Any warranted part that is scheduled for replacement as required maintenance in the owner's manual supplied, is warranted for the period of time prior to the first scheduled replacement point for that part. If the part fails prior to the first scheduled replacement, the part will be repaired or replaced by B&S at no charge to the owner. Any such part repaired or replaced under warranty will be warranted for the remainder of the period prior to the first scheduled replacement point for the part.
- Add on or modified parts that are not exempted by the Air Resources Board may not be used. The use of any non exempted add on or modified parts by the owner will be grounds for disallowing a warranty claim. The manufacturer will not be liable to warrant failures of warranted parts caused by the use of a non exempted add on or modified part.

3. Consequential Coverage

Coverage shall extend to the failure of any engine components caused by the failure of any warranted emissions parts.

4. Claims and Coverage Exclusions

Warranty claims shall be filed according to the provisions of the B&S engine warranty policy. Warranty coverage does not apply to failures of emissions parts that are not original equipment B&S parts or to parts that fail due to abuse, neglect, or improper maintenance as set forth in the B&S engine warranty policy. B&S is not liable for warranty coverage of failures of emissions parts caused by the use of add-on or modified parts.

**Look For Relevant Emissions Durability Period and Air Index Information  
On Your Small Off-Road Engine Emissions Label**

Engines that are certified to meet the California Air Resources Board (CARB) small off-road Emissions Standard must display information regarding the Emissions Durability Period and the Air Index. Briggs & Stratton makes this information available to the consumer on our emissions labels. The engine emissions label will indicate certification information.

The **Emissions Durability Period** describes the number of hours of actual running time for which the engine is certified to be emissions compliant, assuming proper maintenance in accordance with the Operating & Maintenance Instructions. The following categories are used:

**Moderate:**

Engine is certified to be emissions compliant for 125 hours of actual engine running time.

**Intermediate:**

Engine is certified to be emissions compliant for 250 hours of actual engine running time.

**Extended:**

Engine is certified to be emissions compliant for 500 hours of actual engine running time. For example, a typical walk-behind lawn mower is used 20 to 25 hours per year.

Therefore, the **Emissions Durability Period** of an engine with an **intermediate** rating would equate to 10 to 12 years.

Briggs & Stratton engines are certified to meet the United States Environmental Protection Agency (USEPA) Phase 2 or Phase 3 emissions standards. The Emissions Compliance Period referred to on the Emissions Compliance label indicates the number of operating hours for which the engine has been shown to meet Federal emissions requirements.

For engines less than 225 cc displacement.

Category C = 125 hours, Category B = 250 hours, Category A = 500 hours

For engines of 225 cc or more displacement.

Category C = 250 hours, Category B = 500 hours, Category A = 1000 hours

Not for  
Reproduction



[www.simplicitymfg.com](http://www.simplicitymfg.com)  
[www.snapper.com](http://www.snapper.com)

Briggs & Stratton Power Products Group, L.L.C.  
Copyright © 2011 Briggs & Stratton Corporation  
Milwaukee, WI USA. All Rights Reserved  
[www.BRIGGSandSTRATTON.com](http://www.BRIGGSandSTRATTON.com)