

VANGUARD™ 16.0 GROSS HP†

479 CC

Bore 2.68 in. (68.00 mm)

Stroke 2.60 in. (66.00 mm)

Oil Capacity 48 fl. oz. (1.42 L)

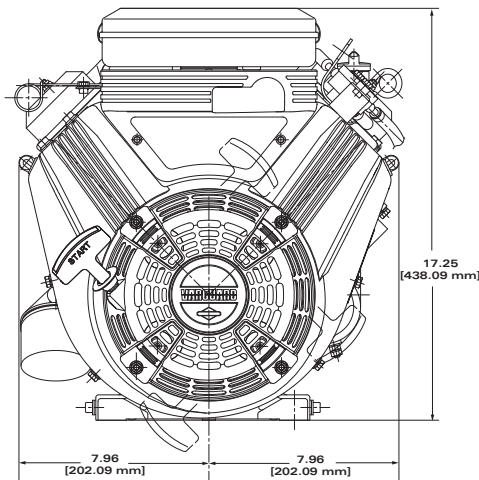
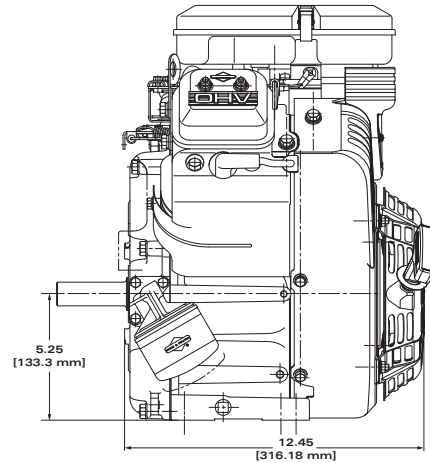

FEATURES:

Float carburetor for consistent easy starting

Dual-Clean™ air cleaner pleated paper filter with a foam pre-cleaner ensures maximum protection for extended engine life

Full pressure lubrication with spin-on oil filter assures controlled lubrication for extended component life

Overhead valve design (OHV) for cooler operation and longer valve life

Buyer protection package provides three-year commercial limited warranty**

MTT	Crankshaft #	P.T.O. Diameter	Drilled & Tapped	Keyway	Length	Starter Position	Controls	Remote Choke	Manual Choke	Cyclonic Air Filter	Flange Mfg.	Oil Cooler	Fuel Pump	Oil Pump with Filter	Key Stop Switch	Fuel Tank (Quarts)	Muffler	Top Governor Speed	Notes
305442																			
0527-F1	692161	1 in.	3/8-24	1/4-Str.	3	9:00	AG/R/MF	X	X	X	X	X	X	X		9		3600	11
305447																			
0178-G2	692168	1 in.	3/8-24	1/4-Str.	2		R	X		X	X	X	X	X		--		3450	6,26
0265-G2	692168	1 in.	3/8-24	1/4-Str.	2		R	X		X	X	X	X	X		--		3200	6,26
0285-G2	692168	1 in.	3/8-24	1/4-Str.	2		R	X		X	X	X	X	X		--		3450	6,26
0293-G2	692168	1 in.	3/8-24	1/4-Str.	2		R	X		X	X	X	X	X		--		3200	6,26
0523-F1	692161	1 in.	3/8-24	1/4-Str.	3	9:00	AG/MF/R	X	X	X	X	X	X	X	X	9		3600	6,11
0568-F1	692161	1 in.	3/8-24	1/4-Str.	3	9:00	AG/MF/R	X	X	X	X	X	X	X	X	9	X	3600	6,11
3075-G1	692161	1 in.	3/8-24	1/4-Str.	3	9:00	AG/MF/R	X	X	X	X	X	X	X	X	--		3600	6,11
3077-G1	692162	1 in.	Threaded 1-14		3-21/32	9:00	AG/R		X	X	X	X	X	X	X	--		3600	6,11
3078-G1	692163	Taper	5/16-24	---	3-21/64	9:00	AG		X	X	X	X	X	X	X	--		3750	6,11
3079-G1	692161	1 in.	3/8-24	1/4-Str.	3		MF/R	X	X	X	X	X	X	X	X	--		3600	6,11,14
3087-G1	845027	1-1/8 in.	7/16-20	1/4-Str.	4	9:00	MF/R		X	X	X	X	X	X	X	--		3600	6,11

†All power levels are stated gross horsepower at 3600 RPM per SAE J1940 as rated by Briggs & Stratton.

(6) Engine equipped with 12 Volt Gear Drive Starter and 16 AMP DC Alternator

(11) PTO Ball Bearing

(14) Suppress Afterfire Solenoid

(26) Engine with out air cleaner

**See www.briggsandstratton.com for warranty details.