

VANGUARD™ 31.0 GROSS HP†

896 CC

Bore 3.37 in. (85.50 mm)

Stroke 3.07 in. (78.00 mm)

Oil Capacity 79 fl. oz. (2.34 L)

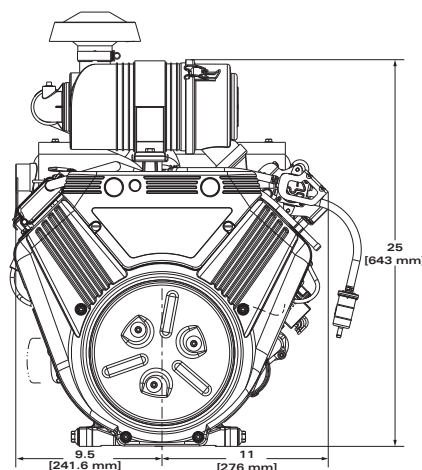
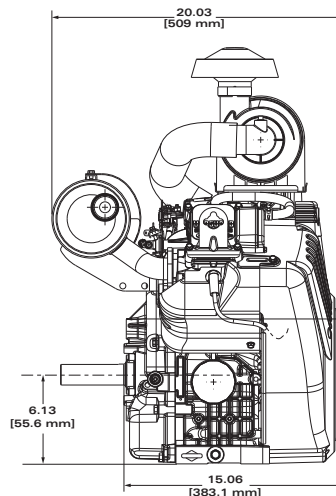

FEATURES:

Advanced Debris Management System allows the engine to run cleaner and cooler, which enhances durability and performance

Cyclonic air filter provides ultimate debris protection and lasts 2X longer than panel-style air cleaner systems

Industrial grade solenoid shift starter assures quick, reliable starts

Full-pressure oil lubrication system with spin-on filter works to keep oil cleaner, which reduces maintenance and extends engine life

Buyer protection package provides three-year commercial limited warranty**

MTT	Crankshaft #	P.T.O. Diameter	Drilled & Tapped	Keyway	Length	Controls	Remote Choke	Manual Choke	Cyclonic Air Filter	Flange Mtg.	Oil Cooler	Fuel Pump	Oil Pump with Filter	Key Stop Switch	Fuel Tank (Quarts)	Muffler	Top Governor Speed	Notes
543477																		
3035-G1	843288	21/64 Taper	5/16-24	----	----	AG		X	X	X	X	X	X	X	--		3750	8,14,15
3048-J1	843290	1-1/8 in.	7/16-20	1/4-Str.	4	MF		X	X	X		X	X	X	--		3600	8,14,15
3065-J1	843290	1-1/8 in.	7/16-20	1/4-Str.	4	MF		X	X	X		X	X	X	--	X	3600	8,14,15
3076-J1	843292	1-1/8 in.	7/16-20	1/4-Str.	3	R	X		X	X		X	X		--		3600	8,14
3079-J1	843291	1-7/16	5/8-18	3/8-Str.	4.5	MF		X	X	X		X	X	X	--		3600	8,14,15
3110-J1	843290	1-1/8 in.	7/16-20	1/4-Str.	4	R	X		X	X		X	X		--	X	3600	8,14
3111-J1	843290	1-1/8 in.	7/16-20	1/4-Str.	4	R	X		X	X		X	X		--		3600	8,14

†All power levels are stated gross horsepower at 3600 RPM per SAE J1940 as rated by Briggs & Stratton.

(8) Engine equipped with 12 Volt Solenoid Shift Starter and 20 AMP DC Alternator

(14) Suppress Afterfire Solenoid

(15) Static Cover Installed