



# Zoom XL<sup>®</sup>

Owner/Operator Manual

Manuel Du Propriétaire/Utilisateur

## Models

915163 – Zoom XL 42  
(SN 030000 +)

915165 – Zoom XL 48  
(SN 030000 +)

915173 – Zoom XL 54  
(SN 030000 +)



The use of any gasoline exceeding 10% ethanol (E10) or 10% MTBE will void the product warranty.

L'utilisation d'une essence contenant plus de 10% d'éthanol (E10) ou de 10% de MTBE annulent la garantie.



EN ENGLISH

FR FRANÇAIS

04699800A 9/13

Printed in USA

# TABLE OF CONTENTS

Safety .....	4	Storage .....	28
Assembly .....	11	Troubleshooting .....	29
Controls And Features .....	13	Service Parts .....	31
Operation .....	14	Accessories .....	31
Maintenance Schedule .....	18	Specifications .....	32
Service And Adjustments .....	20	Warranty .....	33

## INTRODUCTION

### THE MANUAL

Before operation of unit, carefully and completely read your manuals. The contents will provide you with an understanding of safety instructions and controls during normal operation and maintenance.

All reference to left, right, front, or rear are given from operator seated in operation position and facing the direction of forward travel.

### ENGINE MANUAL

The engine on this unit is covered by a separate manual specific to the engine. This manual is included in the literature package that shipped with the unit. Refer to this manual for engine service recommendations. If the engine manual is not available, contact the engine manufacturer for a replacement manual.

### MODEL AND SERIAL NUMBERS

When ordering replacement parts or making service inquiries, know the Model and Serial numbers of your unit and engine.

Numbers are located on the product registration form in the unit literature package.

They are printed on a serial number label, located on the frame of your unit Figure 1.

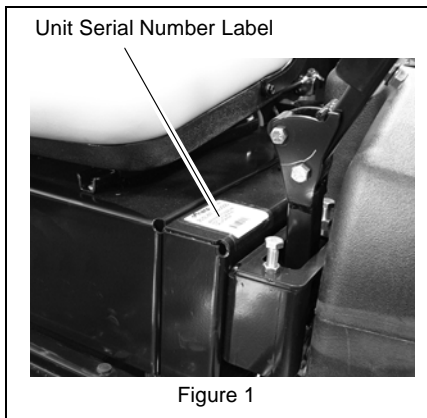

- Record Unit Model and Serial numbers here.

- Record Engine Model and Serial numbers here.

### PRODUCT REGISTRATION

The Ariens dealer must register the product at the time of purchase. Registering the product will help the company process warranty claims or contact you with the latest service information. All claims meeting requirements during the limited warranty period will be honored, whether or not the product registration card is returned. Keep a proof of purchase if you do not register your unit.

**Customer Note:** If the dealer does not register your product, please fill out, sign, and return the product registration card to Ariens.

## UNAUTHORIZED REPLACEMENT PARTS

Use only Ariens replacement parts. The replacement of any part on this unit with anything other than an Ariens authorized replacement part may adversely affect the performance, durability, and safety of this unit and may void the warranty. Ariens disclaims liability for any claims or damages, whether warranty, property damage, personal injury or death arising out of the use of unauthorized replacement parts.

## DELIVERY

**Customer Note:** If you have purchased this product without complete assembly and instruction by your retailer, it is your responsibility to:

- Read and understand all assembly instructions in this manual. If you do not understand or have difficulty following the instructions, contact your nearest Ariens Dealer for assistance.

**NOTICE:** To locate your nearest Ariens Dealer, go to [www.ariens.com](http://www.ariens.com) on the Internet.



**WARNING:** Improper assembly or adjustments can cause serious injury.

## Before Attempting To Operate Your Unit:

1. Make sure all assembly has been properly completed.
2. Understand all Safety Precautions provided in the manuals.
3. Review control functions and operation of the unit. Do not operate the unit unless all controls function as described in this manual.
4. Review recommended lubrication, maintenance and adjustments.
5. Review Limited Warranty Policy.
6. Fill out a product registration card and return the card to the Ariens Company or go to [www.ariens.com](http://www.ariens.com).

## DISCLAIMER

Ariens reserves the right to discontinue, change, and improve its products at any time without notice or obligation to the purchaser. The descriptions and specifications contained in this manual were in effect at printing. Equipment described within this manual may be optional. Some illustrations may not be applicable to your unit.

# SAFETY



**WARNING:** This cutting machine is capable of amputating hands and feet and throwing objects. Failure to observe the safety instructions in the manuals and on decals could result in serious injury or death.

Slopes are a major factor related to loss-of-control and tip-over accidents. Operation on all slopes requires extra caution.

Tragic accidents can occur if the operator is not alert to the presence of children. Never assume that children will remain where you last saw them.

Gasoline is extremely flammable and the vapors are explosive, handle with care.

Disengage attachment, stop unit and engine, remove key, engage parking brake, and allow moving parts to stop before leaving operator's position.



**CAUTION: POTENTIALLY HAZARDOUS SITUATION!** If not avoided, MAY RESULT in minor or moderate injury. It may also be used to alert against unsafe practices.

## NOTATIONS

**NOTICE:** General reference information for proper operation and maintenance practices.

**IMPORTANT:** Specific procedures or information required to prevent damage to unit or attachment.

## SAFETY DECALS AND LOCATIONS

ALWAYS replace missing or damaged Safety Decals. Refer to Figure 2 for safety decal locations.

## SAFETY ALERTS



Look for these symbols to point out important safety precautions. They mean:



- Attention!
- Personal Safety Is Involved!
- Become Alert!
- Obey The Message!

The safety alert symbol is used in decals and with this manual. Understand the safety message. It contains important information about personal safety.



**DANGER: IMMINENTLY HAZARDOUS SITUATION!** If not avoided, WILL RESULT in death or serious injury.



**WARNING: POTENTIALLY HAZARDOUS SITUATION!** If not avoided, COULD RESULT in death or serious injury.

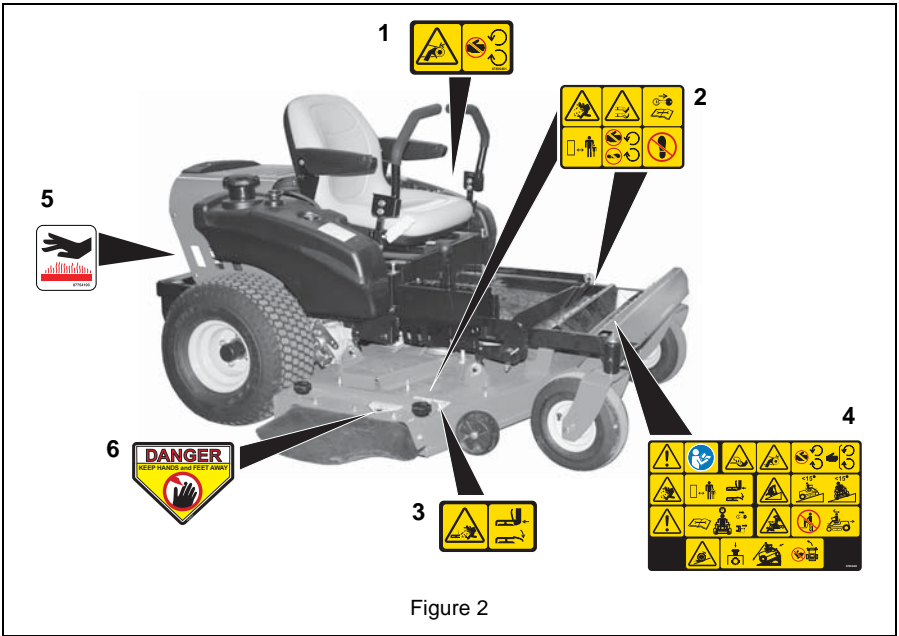



Figure 2

**1. DANGER!**



Discharge Hazard – NEVER operate unit without discharge chute in operating position. Thrown objects can cause injury or damage.



Do not operate mower unless all guards are in operating position or bagger is attached.

**2. DANGER!**



Discharge Hazard - NEVER direct discharge toward people, pets or property. Thrown objects can cause injury or damage.



Dismemberment Hazard – NEVER stick hands or feet under deck or shielded areas.



Shut off engine, remove key, and read manual before servicing or making adjustments to unit.



Keep children and others away from unit while unit is in operation.



Keep feet and hands away from all rotating or moving parts.



DO NOT step or stand in this area.

### 3. DANGER!



Discharge Hazard – NEVER operate unit without discharge chute in operating position. Thrown objects can cause injury or damage.

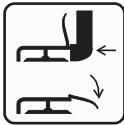

Do not operate mower unless all guards are in operating position or bagger is attached.

### 4. DANGER!



DANGER!



Read and understand the operator's manual before operating unit.

### 4.1 Dismemberment Hazard



To avoid dismemberment hazard do not put hands near rotating blades.



To avoid dismemberment hazard do not put hands near moving belts.



Keep hands away from all rotating or moving parts.

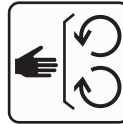

Keep all guards and shields in place.

### 4.2 Discharge Hazard



Discharge Hazard – NEVER direct discharge toward people, pets or property. Thrown objects can cause injury or damage.

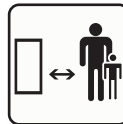

Keep children and others away from unit while unit is in operation.

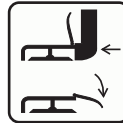

Do not operate mower unless all guards are in operating position or bagger is attached.

### 4.3 Tipping Hazard



Avoid tipping hazard.



DO NOT operate on slopes over  $15^\circ$ .



DO NOT operate on slopes over  $15^\circ$ .

#### 4.4 Service Hazard



Before servicing unit do the following:



Read owners manual before servicing or making adjustments to unit.



Set parking brake.

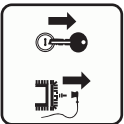

Remove key and disconnect spark plug before servicing or making adjustments to unit.

#### 4.5 Bystander Hazard



DO NOT operate the unit in the presence of bystanders.



Do not carry passengers.



Look behind when operating the unit in reverse.

#### 4.6 Loss of Traction Hazard



If loss of traction is experienced do the following:

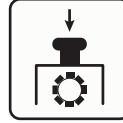

Disengage PTO.



Look before backing. Proceed off slope slowly.



Do not try to turn or speed up.

#### 5. HOT SURFACES!



DO NOT touch parts which are hot from operation. ALWAYS allow parts to cool.

#### 6. DANGER!



Keep hands and feet away.

#### EMISSION CONTROL SYSTEM

This equipment and/or its engine may include exhaust and evaporative emissions control system components required to meet U.S. Environmental Protection Agency (EPA) and/or California Air Resources Board (CARB) regulations. Tampering with emission controls and components by unauthorized personnel may result in severe fines or penalties. Emission controls and components can only be adjusted by an Ariens Company

dealer or an authorized engine manufacturer's service center. Contact your Ariens Company Equipment Retailer concerning emission controls and component questions.

## **SAFETY RULES**

If unit is to be used by someone other than original purchaser; loaned, rented or sold, ALWAYS provide this manual and any needed safety training before operation.

Only the user can prevent and is responsible for accidents or injuries occurring to themselves, other people or property.

Read, understand, and follow all safety practices in Owner/Operator Manual before assembling, using or working on this mower.

ALWAYS remove key from ignition and wire from spark plug before assembly, or working on this unit.

Inspect unit before each use for: missing or damaged decals and shields, correctly operating safety interlock system, and deterioration of grass catchers. Replace or repair as needed.

ALWAYS check overhead and side clearances carefully before operation.

ALWAYS be aware of traffic when crossing or operating along streets or curbs.

Keep children, people, and pets away. Be alert and shut off unit if anyone enters work area. Keep children under watchful care of a responsible adult.

NEVER allow children to operate or play on or near unit.

Keep area of operation clear of all toys, and debris. Thrown objects can cause injury.

Stay alert for hidden hazards, holes, and ruts.

Avoid uneven or rough terrain. DO NOT operate near drop-offs, ditches, or embankments. Unit can suddenly turn over if a wheel is over the edge of a cliff or ditch, or if a edge caves in.

Dust, fog, etc. can reduce vision and cause an accident. Operate unit only when there is good visibility and light.

Data indicates that operators, age 60 and above, are involved in a larger percentage of riding mower related injuries. These operators should evaluate their ability to operate the riding mower safely enough to protect themselves and others from serious injury.

Wear adequate safety gear, sturdy shoes, and protective gloves.

Only trained adults may operate unit. Training includes being familiar with controls and actual operation.

NEVER operate unit after or during the use of medication, drugs or alcohol.

NEVER allow anyone to operate this unit when their alertness or coordination is impaired.

DO NOT wear loose clothing or jewelry and tie back hair that may get caught in rotating parts.

Protect eyes, face and head from objects that may be thrown from unit. Wear appropriate hearing protection. Always wear safety goggles or safety glasses with side shields when operating mower.

Avoid sharp edges. Sharp edges can cut. Moving parts can cut off fingers or a hand.

ALWAYS keep hands and feet away from all rotating parts during operation. Rotating parts can cut off body parts.

ALWAYS keep hands away from all pinch points.

Start and operate unit only when seated in operator's position. Steering control levers must be in neutral, PTO disengaged and parking brake set when starting engine.

ALWAYS keep body and hands away from pin holes or nozzles which eject hydraulic fluid under pressure.

DO NOT touch unit parts which might be hot from operation. Allow parts to cool before attempting to maintain, adjust or service.

NEVER place your hands or any part of your body or clothing inside or near any moving part while unit is running.

NEVER direct discharge towards persons or property. Thrown objects may ricochet back towards operator. ALWAYS stand clear of the discharge area.

ALWAYS disengage attachment, stop unit and engine, remove key, engage parking brake, and allow moving parts to stop before leaving operator's position.

Use extreme caution on gravel surfaces.

Disengage PTO when attachment is not in use and when crossing gravel surfaces.

DO NOT operate unit if safety interlock system is damaged or disabled. Check safety interlock before each use.

ALWAYS remove key to prevent unauthorized use.

DO NOT operate at too fast a rate. Slow down before turning.



Stop engine before removing grass catcher or unclogging chute.

DO NOT mow on wet grass. Reduced traction could cause sliding.

DO NOT mow with the deck access plate open. Always make sure the access plate is down, or secured down, with the hardware.

DO NOT try to stabilize the machine by putting your foot on the ground.

Know the weight of loads. Limit loads to those you can safely control and the unit can safely handle.

ALWAYS keep protective structures, guards and panels in good repair, in place and securely fastened.

Do not operate without either entire grass catcher or the discharge guard in place.

DO NOT operate in reverse unless absolutely necessary. ALWAYS look down and behind before and while backing; especially for children.

Follow the manufacturer's recommendations for wheel weights or counterweights to improve stability when using attachments.

NEVER carry passengers – especially children – even with blades off.

Use extra care when approaching blind corners or objects that may obscure vision of hidden obstacles and children.

If you cannot back up a slope or you feel uneasy on it, do not mow it.

Operation on slopes may lead to loss of steering control. When operating on slopes be prepared to react to an emergency situation:

- Return steering levers to neutral position.
- Immediately set parking brake.
- Turn off PTO and engine.

Mow up and down slopes, not across them.

Use slow speed on any slope. Tires may lose traction on slopes even though the brakes are functioning properly.

Keep all movements on the slope *slow* and *gradual*. DO NOT make sudden changes in speed or direction.

Use extra care while operating machines with grass catcher or other attachments. They can affect stability of the machine.

Avoid starting, stopping, or turning on a slope. If tires lose traction, disengage the blades and proceed slowly *straight* down the slope.

DO NOT operate on slopes over 15°.

DO NOT park on slopes unless necessary. If unit is parked on a slope, ALWAYS chock or block wheels and set parking brake.

DO NOT disengage or bypass transmission and coast downhill.

Tow only with a machine that has a hitch designed for towing. Do not attach towed equipment except at the hitch point.

Follow the manufacturer's recommendations for weight limits for towed equipment and towing on slopes.

NEVER allow children or others in or on towed equipment.

On slopes, the weight of the towed equipment may cause loss of traction and loss of control. Travel slowly and allow extra distance to stop.

Use extra care when loading or unloading unit onto trailer or truck.

Secure unit chassis to transport vehicle. NEVER secure from rods or linkages that could be damaged.

DO NOT transport machine while engine is running.

ALWAYS turn off power to attachment and shut off fuel when transporting unit.

Keep unit free of grass clippings, leaves, and other debris. Clean up oil or fuel spills.

This product is equipped with an internal combustion type engine. DO NOT use unit on or near any unimproved, forest-covered or brush covered land unless exhaust system is equipped with a spark arrester meeting applicable local, state or federal laws. A spark arrester, if it is used, must be maintained in effective working order by operator.

Fuel is highly flammable and its vapors are explosive. Handle with care. Use only an approved gasoline container with an appropriately sized dispensing spout.

NO smoking, NO sparks, NO flames. ALWAYS allow engine to cool before servicing.

NEVER fill fuel tank when engine is running or hot from operation.

NEVER fill or drain fuel tank indoors.

NEVER overfill fuel tank.

Replace fuel cap securely and clean up spilled fuel.

NEVER fill containers inside a vehicle or on a truck or trailer bed with a plastic liner. Always place containers on the ground away from your vehicle before filling.

When practical, remove gas-powered equipment from the truck or trailer and refuel it on the ground. If this is not possible, then refuel such equipment on a trailer with a portable container, rather than from a gasoline dispenser nozzle.

Keep the nozzle in contact with the rim of the fuel tank or container opening at all times until fueling is complete. Do not use a nozzle lock-open device.

If fuel is spilled on clothing, change clothing immediately.

Avoid Electric Shock. Objects contacting both battery terminals at the same time may result in injury and unit damage. DO NOT reverse battery connections.

Explosive Gases from battery can cause death or serious injury. Poisonous battery fluid contains sulfuric acid and its contact with skin, eyes or clothing can cause severe chemical burns.

NO flames, NO sparks, NO smoking near battery.

ALWAYS wear safety glasses and protective gear near battery. Use insulated tools.

Battery posts, terminals and related accessories contain lead and lead compounds, chemicals known to the State of California to cause cancer and reproductive harm. Wash hands after handling.

ALWAYS keep batteries out of reach of children.

Reverse connections may result in sparks which can cause serious injury. Always connect positive (+) lead of charger to positive (+) terminal, and negative (-) lead to negative (-) terminal.

ALWAYS disconnect negative (-) cable FIRST and positive (+) cable SECOND. ALWAYS connect positive (+) cable FIRST, and negative (-) cable SECOND.

A frozen battery can explode and result in death or serious injury. DO NOT charge or jump start a battery containing frozen fluid. Thaw the battery before putting on a charger or jump starting.

ALWAYS keep protective structures, guards, and panels in good repair, in place and securely fastened. NEVER modify or remove safety devices.

DO NOT change engine governor settings or over-speed engine.

Fumes from engine exhaust can cause injury or death. DO NOT run engine in an enclosed area. Always provide good ventilation. ALWAYS maintain unit in safe operating condition. Damaged or worn out muffler can cause fire or explosion.

Stop and inspect equipment if you strike an object or if there is an unusual vibration. Repair, if necessary, before restarting. Never make adjustments or repairs with the engine running.

Mower blades are sharp and can cut you. Wrap the blade(s) or wear gloves, and use extra caution when servicing them. NEVER weld or straighten mower blades.

Rotation of one blade may cause rotation of the other blades.

Check brake operation frequently. Adjust and service as required.

Keep all hardware properly tightened.

Stored energy in springs can cause injury.

Maintain or replace safety and instruction labels, as necessary.

Never store the machine or fuel container inside a building where there is an open flame, such as a water heater.

Shut off fuel (if provided) and allow engine to cool completely before storing in closed area or covering unit.

Clean grass and debris from unit, especially from around muffler and engine, to help prevent fires.

For extended storage, clean unit thoroughly. See Engine Manual for proper storage.

Use only attachments or accessories designed for your unit.

Check attachment components frequently. If worn or damaged, replace with manufacturer's recommended parts.

# ASSEMBLY



**WARNING:** AVOID INJURY.  
Read and understand the entire  
*Safety* section before proceeding.

## Tools Required

- Adjustable wrench
- 9/16" wrench
- Petroleum jelly or dielectric grease.

## Unpack Unit

Remove unit and all other components from the shipping container. Engage transmission bypass lever (see *MOVING UNIT MANUALLY* on page 17). Push unit from container onto a level surface. Disengage transmission bypass lever.

## Connect Battery

See *Battery Removal and Installation* on page 23 and perform steps 4 and 5 in the installation section.

## Place Unit in Operating Position

Figure 3

**NOTICE:** The seat is shipped with the seat positioned as far back as possible.

1. Push steering levers aside and tip seat up.
2. Adjust the seat as needed (see *Adjusting Seat* on page 16).
3. Remove hardware from top hole of the steering lever Figure 3. Slide steering lever back to align slot with hole at the top of the steering pivot arm.

**NOTICE:** Do not tighten hardware before reviewing *ADJUSTING STEERING LEVERS* on page 24. If no adjustment is desired tighten hardware.

4. Adjust steering levers (see *ADJUSTING STEERING LEVERS* on page 24).

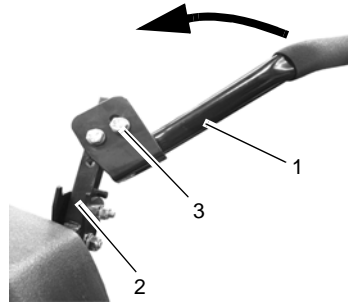

1. Steering Lever
2. Steering Pivot Arm
3. Steering Lever Hardware

Figure 3

## Place Discharge Chute in Operating Position



**WARNING:** Do not operate  
mower unless the discharge chute  
is in the operating position.

1. Remove and discard the nuts holding the discharge chute in transport position.
2. Remove the plastic knobs from the chute hardware and use to mount the chute to the deck in operating position. See Figure 4.

### Transport Position



### Operating Position



Figure 4

## Check Tire Pressure



### **CAUTION:** Avoid injury!

Explosive separation of tire and rim parts is possible when they are serviced incorrectly:

- Do not attempt to mount a tire without the proper equipment and experience to perform the job.
- Do not inflate the tires above the recommended pressure.
- Do not weld or heat a wheel and tire assembly. Heat can cause an increase in air pressure resulting in an explosion. Welding can structurally weaken or deform the wheel.
- Do not stand in front or over the tire assembly when inflating. Use a clip-on chuck and extension hose long enough to allow you to stand to one side.

## Check Engine Oil Level

Refer to Engine Manual.

## Level Mower Deck

See *LEVELING AND ADJUSTING PITCH OF MOWER DECK* on page 21.

## Fill Fuel Tank

Fill fuel tank. **DO NOT OVERFILL!** See *FILLING FUEL TANK* on page 16.

## Adjust Seat

See *Adjusting Seat* on page 16.

## Check Safety Interlock System



**WARNING:** Safety interlock failure and improper operation of unit can result in death or serious injury. Check system before each use to make sure it is functioning properly.

See *Safety Interlock System* on page 14.

## Check function of all controls

See *Operation* on page 14.

See *Specifications* on page 32.

## CONTROLS AND FEATURES

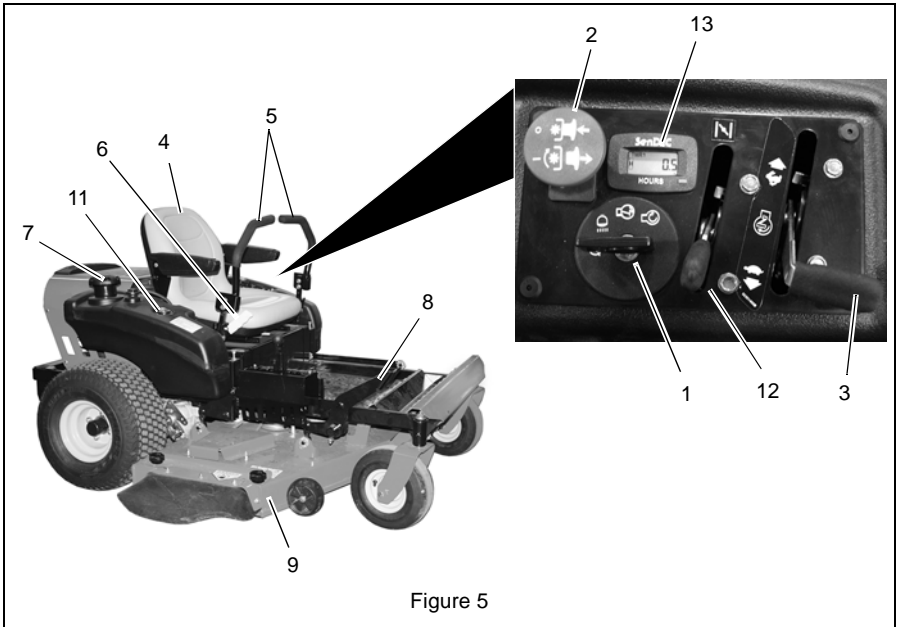

Figure 5

1. Ignition Switch
2. PTO Switch
3. Throttle Lever
4. Seat
5. Steering Levers
6. Parking Brake
7. Fuel Tank
8. Mower Lift Pedal
9. Mower Deck
10. Discharge Chute
11. Fuel Gauge
12. Choke Control
13. Hour meter

# OPERATION



**WARNING:** AVOID INJURY.  
Read and understand the entire Safety section before proceeding.

## CONTROLS AND FEATURES

See Figure 5 for all controls and features locations.

### Safety Interlock System



**WARNING:** Safety interlock failure and improper operation of unit can result in death or serious injury. Check system before each use to make sure it is functioning properly.

Perform the following tests to ensure the safety interlock system is working properly. If the unit does not perform as stated contact your Ariens dealer for repairs.

Test	Steering Lever	PTO	Parking Brake	Engine
1	Neutral Position	Off	Engaged	Starts
2	Neutral Position	On	Engaged	Doesn't Start
3	Neutral Position	Off	Disengaged	Doesn't Start
4*+	Out of Neutral Position	Off	Disengaged	Shuts Off
5*+	Neutral Position	On	Engaged	Shuts Off

\* Test with engine running.  
+ Operator lifts off seat.

### Ignition Switch

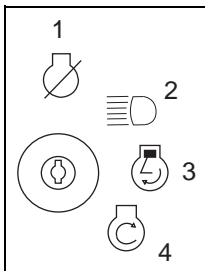

Operate ignition switch with a removable key. Ignition switch has four positions: Stop (1), Headlight (2), Run (3), Start (4). See on page 17 for detailed instructions on how to start engine.

### Throttle Lever



Fast (1) – Increases engine speed.

Slow (2) – Decreases engine speed.

### Choke Control

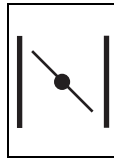

Use to start a cold engine. Push the choke lever away from operator position to start a cold engine. Pull the choke lever toward the operator position when the engine starts to run smoothly.

**NOTICE:** Do not choke a warm engine.

### Parking Brake

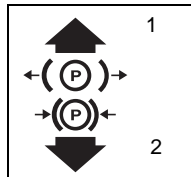

Engages (2) and disengages (1) parking brake.

### Power Take-Off (PTO) Switch

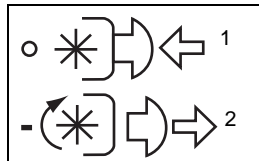

Engages (2) and disengages (1) mower blades.

### Hour Meter

Press and release the toggle button to shift between different functions.

Press and hold the toggle button to reset the timer or clear a service message.

The hour meter has three functions:

**Hour Meter:** measures the amount of time the engine has been run. This time cannot be cleared.

**Timer (TMR1):** measures the time spent on individual jobs.

Press and hold the toggle button to reset the timer to zero. TMR1 will then start measuring engine run time until it is reset to zero again.

**Service Alert (Chg Oil, Chg H Oil & Filter, SVC Airfilter):** reminds operators of the maintenance interval for changing the engine oil, changing the hydraulic oil and filter and servicing the air filter.

The alert starts counting down two hours before the maintenance is due. The meter flashes the word, "Now," when it reaches the maintenance time.

Press and hold the toggle button to reset the maintenance clock to zero after performing the service.

**NOTICE:** The hour meter is preprogrammed for the initial oil change at 25 hours and for 100 hours thereafter. The hour meter is programmed for the initial hydraulic oil and filter change at 75 hours and for 400 hours thereafter.

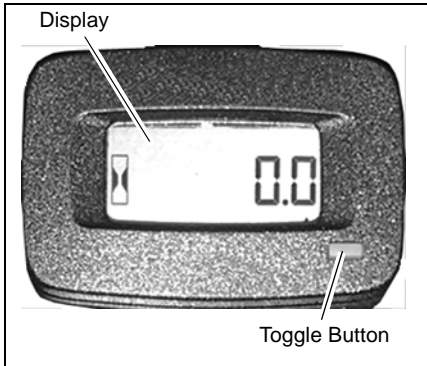

## Steering Levers

- Reverse (1) – Pull both steering levers backward.
- Forward (2) – Push both steering levers forward.
- Left (3) – Pull left steering lever back or push right steering lever forward or a combination of both.
- Right (4) – Pull right steering lever back or push left steering lever forward or a combination of both.

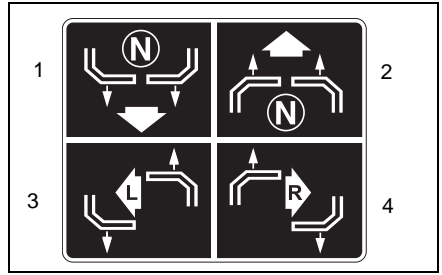

**NOTICE:** To stop, return both steering levers to neutral.

**NOTICE:** The steering levers must be in the neutral position to start the engine.

**NOTICE:** The parking brake must be disengaged prior to moving the steering levers from the neutral position.

## Mower Lift Pedal

Figure 6

Raises and lowers the deck.

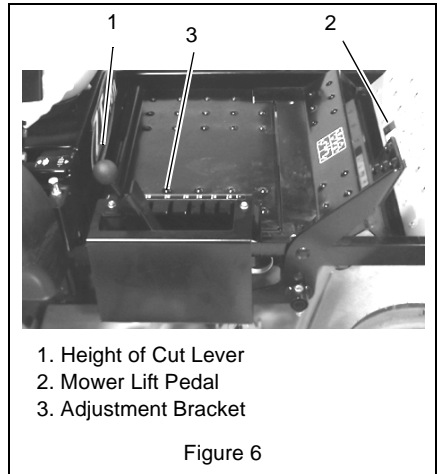

1. Height of Cut Lever
2. Mower Lift Pedal
3. Adjustment Bracket

Figure 6

**NOTICE:** The height of cut lever is used to set the height of the mower deck. See *Specifications* on page 32 for cutting height dimensions.

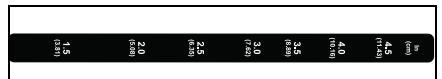

Press mower lift pedal and place height of cut lever to desired adjustment notch.

**NOTICE:** Adjusting the seat further forward will help increase the leverage in lifting the mower deck (see *Adjusting Seat* on page 16).

## Adjusting Seat

Lift adjustment lever and slide seat forward or backward to the desired position.

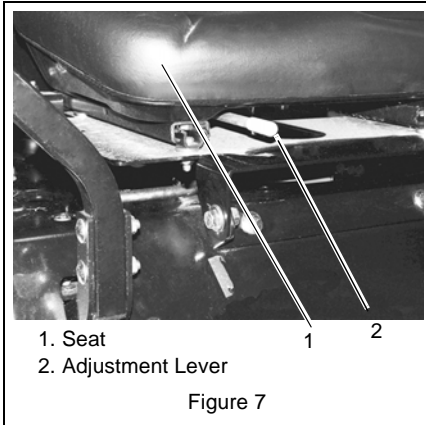

## FILLING FUEL TANK

To add fuel to the fuel tank:

1. Clean fuel caps and surrounding area to prevent dust, dirt, and debris from entering fuel tanks.
2. Remove fuel caps.

**IMPORTANT:** Refer to Engine Manual for correct type and grade of fuel.

3. Fill fuel tank to the bottom of filler neck.  
See *Specifications* on page 32 for fuel tank capacity.

**IMPORTANT:** DO NOT OVERFILL! This equipment and/or its engine may include evaporative emissions control system components, required to meet EPA and/or CARB regulations, that will only function properly when the fuel tank has been filled to the recommended level. Overfilling may cause permanent damage to evaporative emissions control system components. Filling to the recommended level ensures a vapor gap required to allow for fuel expansion. Pay close attention while filling the fuel tank to ensure that the recommended fuel level inside the tank is not exceeded. Use a portable gasoline container with an appropriately sized dispensing spout when filling the tank. Do not use a funnel or other device that obstructs the view of the tank filling process.

4. Replace fuel cap and tighten.
5. ALWAYS clean up spilled fuel.

## GASOLINE

**IMPORTANT:** ALWAYS use gasoline that meets the following guidelines:

- Clean, fresh gasoline.
- A minimum of 87 octane/87 AKI (91 RON). High altitude use may require a different octane. Consult your engine manual.
- Gasoline with up to 10% ethanol (gasohol) or up to 10% MTBE (methyl tertiary butyl ether) is acceptable.
- Use of any gasoline other than those approved above will void the engine warranty. If the pumps are not marked for the content of alcohol or ethers, check ethanol and MTBE levels with the fuel supplier.
- Do not modify the fuel system to use different fuels.
- Never mix oil and gasoline.

**NOTICE:** All gasoline is not the same. If the engine experiences starting or performance problems after using a new gasoline, switch to a different fuel provider or fuel brand.

**IMPORTANT:** Excessively oxygenated or reformulated fuels (fuels blended with alcohols or ethers) can damage the fuel system or cause performance problems. If any undesirable operating problems occur, use a gasoline with a lower percentage of alcohol or ether.

## Fuel Stabilizer

Gasoline left in the fuel system for extended periods without a stabilizer will deteriorate, resulting in gum deposits in the system. These deposits can damage the carburetor and the fuel hoses, filter and tank. Prevent deposits from forming in the fuel system during storage by adding a quality fuel stabilizer to the fuel. Follow the recommended mix ratio found on the fuel stabilizer container.

## STOPPING IN AN EMERGENCY



**WARNING:** Operating unit on slopes may lead to loss of steering control. When operating on slopes be prepared to react to an emergency situation.

1. Return steering levers to neutral position.
2. Immediately set parking brake.
3. Turn off PTO and engine.



**NOTICE:** This unit is not equipped with the return to neutral function. The control arms must be manually brought back to neutral from the forward position.

## MOVING UNIT MANUALLY



**WARNING:** DO NOT disengage or bypass transmission and coast downhill.

Disengage (2) transmission bypass levers to drive unit and engage (1) transmission bypass levers to push unit manually Figure 8.

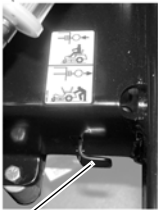
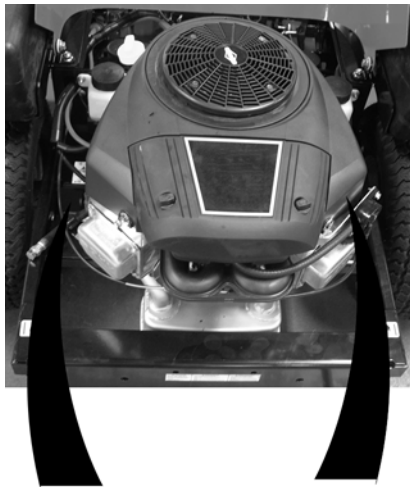

1



2

1. Transmission Bypass Lever Engaged
2. Transmission Bypass Lever Disengaged

Figure 8

## STARTING AND SHUTTING OFF ENGINE

### Starting the Engine

**NOTICE:** Disengage the PTO, engage the parking brake, and place the steering levers in neutral prior to starting the engine.

1. If the engine is cold, push the choke control away from operator position to start. If the engine is warm or hot, do not use choke.
2. Move the throttle to 1/3 Fast position. See Engine Manual for detailed instructions.

**IMPORTANT:** DO NOT operate starter for more than 15 seconds per minute as damage can occur.

3. Turn ignition key to start position and release once the engine has started.
4. Pull the choke lever toward operator position when the engine is warm. Wait until the engine is running smoothly before operation.

**IMPORTANT:** Let the engine warm up several seconds to several minutes depending on outside temperature.

### Stopping the Engine

1. Stop unit.
2. Disengage PTO.
3. Set throttle lever to slow.
4. Turn ignition switch to off position and remove key.
5. Set parking brake.

## OPERATING MOWER

1. Start engine.
2. Set throttle lever to fast.

**IMPORTANT:** Never engage PTO if mower is plugged with grass or other material.

3. Engage PTO to start mower blades.

**NOTICE:** The parking brake must be disengaged prior to moving the steering levers from the neutral lockout position.

4. Release parking brake.
5. Use steering levers to move the unit.
6. Disengage PTO to stop mower blades.

## TRANSPORTING UNIT

ALWAYS shut off engine, set parking brake, remove key, and close fuel shut-off valve or drain fuel when transporting unit on a truck or trailer. Tie unit down securely. Do not tie down by linkages, guards, cables or other parts that may be damaged.

## FOR BEST PERFORMANCE

- Cut grass when it is dry.
- Keep mower blades sharp.
- Keep mower deck properly leveled.
- Adjust anti-scalp rollers to prevent scalping.
- Do not set height of cut too low. For very tall grass, mow twice.
- Do not travel too fast.
- Mow with the engine set at full throttle.

- When mulching, only remove 1/3 of grass length per cutting.
- Discharge clippings into areas already cut.
- Vary cutting pattern with each mowing.
- Do not allow grass or debris to collect inside of mower deck. Clean after each use.

## MAINTENANCE SCHEDULE



**WARNING: AVOID INJURY.**  
Read and understand the entire *Safety* section before proceeding.

**NOTICE:** To have full access to the engine, the seat must be tipped forward (see *TIPPING SEAT FORWARD* on page 20) and the hood opened (see *OPENING AND CLOSING HOOD* on page 20).

**IMPORTANT:** Proper maintenance can prolong the life of unit. The following chart shows the recommended service schedule. Refer to the maintenance instructions in the Engine Manual for additional information.

Interval	Task	Action
Each Use	Check Safety Interlock System	<p><b>WARNING:</b> Safety interlock system failure and improper operation of unit can result in death or serious injury. Test this system each time the unit is operated. If this system does not function as described, do not operate until repairs are made (see <i>Safety Interlock System</i> on page 14).</p>
	Check Parking Brake	Engage parking brake and engage transmission bypass lever (see <i>MOVING UNIT MANUALLY</i> on page 17). Push unit. If unit rolls, contact your Ariens Dealer.
	Clean Unit	Clean engine, battery, seat, mower deck, etc. of all dirt and debris. Do not use solvents, hard cleaners, or abrasives. <b>NOTICE:</b> Protect painted surfaces with automotive type wax. <b>IMPORTANT:</b> Do not spray the unit with water, especially when the unit is warm from operation. Water can seep into bearings and damage them.
	Check Tires	See <i>Specifications</i> on page 32 for correct tire pressure. <p><b>CAUTION:</b> Avoid injury! Explosive separation of tire and rim parts is possible when they are serviced incorrectly:</p> <ul style="list-style-type: none"> <li>• Do not attempt to mount a tire without the proper equipment and experience to perform the job.</li> <li>• Do not inflate the tires above the recommended pressure.</li> <li>• Do not weld or heat a wheel and tire assembly. Heat can cause an increase in air pressure resulting in an explosion. Welding can structurally weaken or deform the wheel.</li> <li>• Do not stand in front or over the tire assembly when inflating. Use a clip-on chuck and extension hose long enough to allow you to stand to one side.</li> </ul>

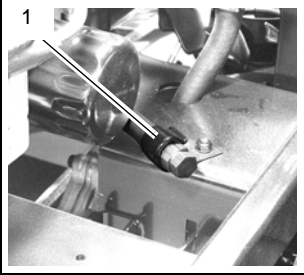
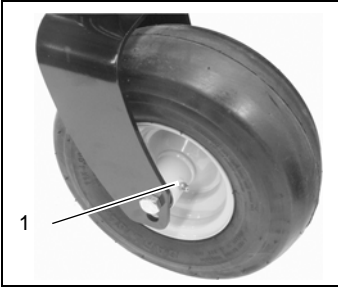
Interval	Task	Action
Each Use	Check Mower Blades	<b>CAUTION:</b> Check for worn or damaged mower blades.
	Follow Engine Manual Maintenance Schedule	Perform scheduled engine maintenance. Refer to Engine Manual for detailed instructions. <b>NOTICE:</b> To drain the oil, use the oil drain hose (1) supplied with unit, not the drain plug that is shown in the Engine Manual. 
25 Hours or Every Season	Check Battery	Keep battery and battery terminals clean (see <i>Cleaning Battery and Battery Cables</i> on page 23).
	Lubricate Unit	Apply grease to zerk (1) on each front wheel 
50 Hours or Every Season	Check Fasteners	Check mower blade mounting hardware and all other fasteners. Replace fasteners that are missing or damaged. Tighten all nuts and bolts to the correct torque value.
100 Hours or Every Season	Check All Belts	Replace worn or deteriorated belts. <ul style="list-style-type: none"> <li>• Check hydrostatic belt (see <i>REPLACING HYDROSTATIC BELT</i> on page 26 for hydrostatic belt location).</li> <li>• Check PTO belt (see <i>REPLACING PTO BELT</i> on page 25 for PTO belt location).</li> </ul>

## SERVICE AND ADJUSTMENTS



**WARNING: AVOID INJURY.**  
Read and understand the entire  
Safety section before proceeding.

### TIPPING SEAT FORWARD

Move steering levers to neutral position and rotate handles outward. Tip seat forward.

Seat Tipped Forward

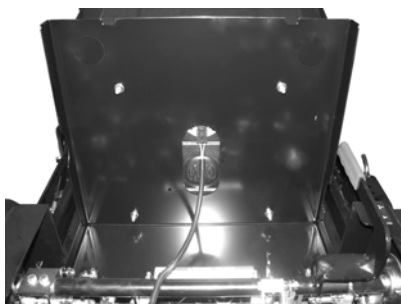

Figure 9

### OPENING AND CLOSING HOOD

To open, pull up on the back of the hood until hood hits the hood stops. Push down on back of hood to close Figure 10.

Hood tipped open.



Figure 10

### OPENING DECK ACCESS PLATE

1. Put parking brake on.
2. Adjust height of cut lever to 4.5 in. (11.4 cm) position Figure 11.
3. Raise deck access plate.

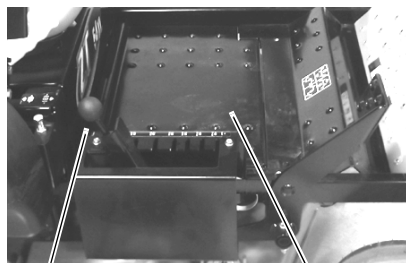

1. Height of Cut Lever
2. Deck Access Plate

Figure 11

### REPLACING MOWER BLADE

#### Remove

Figure 12



**CAUTION:** Mower blades are sharp and can cut you. Wrap the blades or wear gloves, and use extra caution when servicing them.

1. Block mower blades to prevent rotation.
2. Remove mounting hardware and mower blades from mower deck.

#### Install

Figure 12

1. Install mower blades on mower deck with mounting hardware.
2. Torque 5/8" hex bolt to 80 – 120 lbf-ft (108 – 163 N•m).

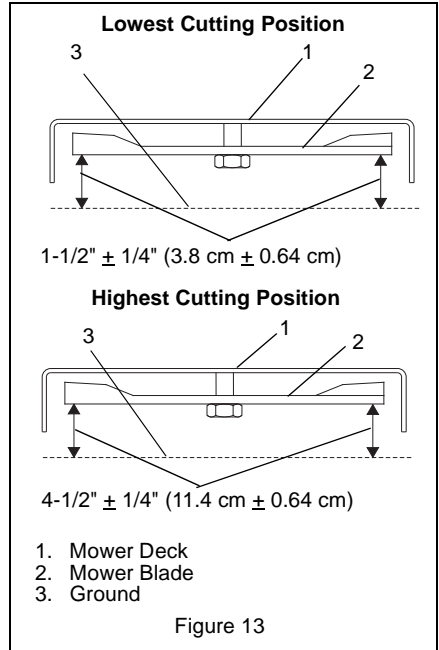
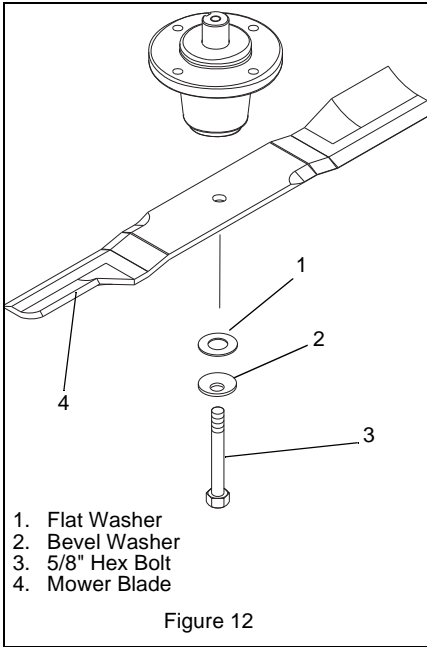

## LEVELING AND ADJUSTING PITCH OF MOWER DECK

**NOTICE:** Adjust on a level surface, with the tires inflated to the correct air pressure (see *Specifications* on page 32).

There are three measurements required to level and adjust the pitch of the mower deck.

1. The distance from the mower blades to the ground.
2. The forward pitch of the mower blades.
3. The pitch of the mower blades from side-to-side.

### The Distance From The Mower Blades To The Ground

Figure 13

- In the lowest cutting position should be 1-1/2" ± 1/4" (3.8 cm ± 0.64 cm).
- In the highest cutting position should be 4-1/2" ± 1/4" (11.4 cm ± 0.64 cm).

### The Forward Pitch Of The Mower Blades

Figure 14

- Should be 0" – 1/4" (6.35 mm) pitched forward.

**NOTICE:** This measurement must be taken when the mower blades ends are facing forward.

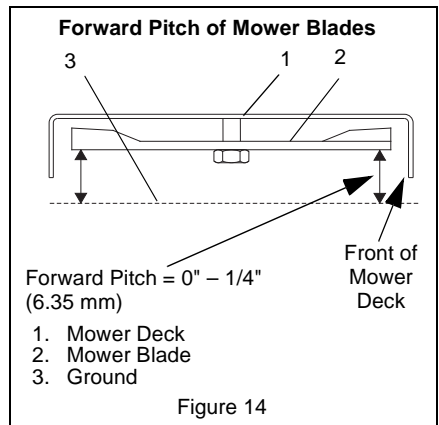

## The Pitch Of The Mower Blades From Side-To-Side

Figure 15

- Should be within 1/4" (6.35 mm) as measured on each side of the mower deck.

**NOTICE:** This measurement must be taken when the mower blade ends are perpendicular (at a right angle) to the frame of the unit.

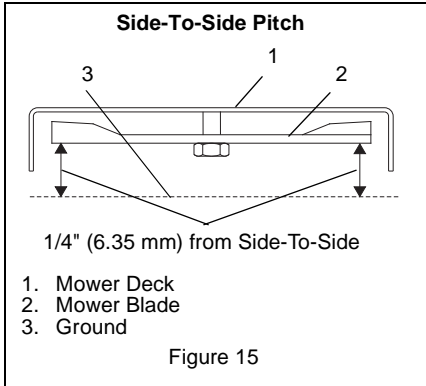

## Adjusting The Mower Deck To Adjust Mower Blade Height And Pitch

Figure 17

**NOTICE:** Adjusting the mower deck will adjust the height and pitch of the mower blades.

1. Adjust the trunnions first and re-take the three measurements required to level and adjust the pitch of the mower deck. These measurements are:
  - a. The distance from the mower blades to the ground.
  - b. The forward pitch of the mower blades.
  - c. The pitch of the mower blades from side-to-side.
2. Repeat step 1 as needed until all three measurements are within the tolerances specified.

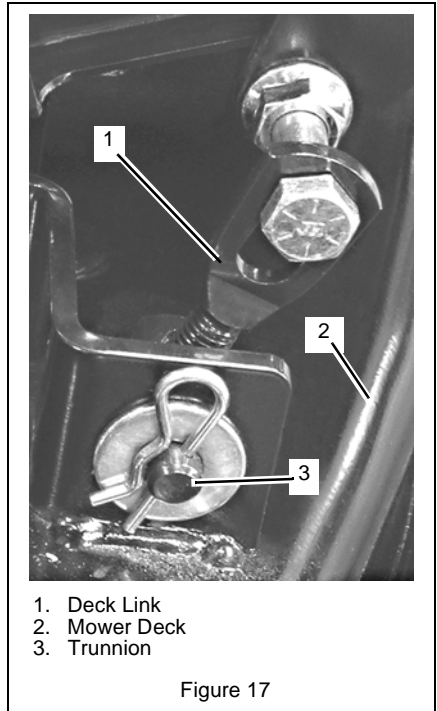
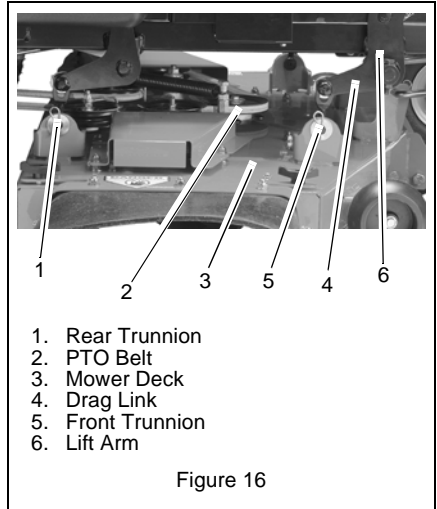

## SERVICING BATTERY

**NOTICE:** Unit comes equipped with a maintenance-free battery that requires no regular maintenance except cleaning the terminals and periodic charging.

This style battery can be replaced with a standard size U1 battery.



**WARNING:** Battery posts, terminals and related accessories contain lead and lead compounds, chemicals known to the State of California to cause cancer and reproductive harm. Wash hands after handling.

### Battery Removal and Installation

#### Remove

Figure 18

1. Tip seat forward (see *TIPPING SEAT FORWARD* on page 20).
2. Disconnect negative (-) cable first, then positive (+) cable.
3. Loosen and remove taptite fastener (2) from battery bracket (1).
4. Remove battery bracket.
5. Remove and properly dispose of old battery.

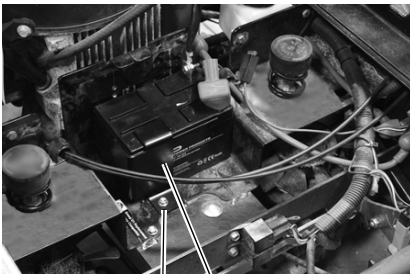

1. Battery Bracket
2. Taptite Fastener

Figure 18

#### Install

Figure 19

1. Remove taptite fastener located by battery decal.
2. Install replacement battery into battery channel.

3. Rotate and align battery bracket lengthwise to battery, ensuring tab corner is flush with battery.
4. Reinstall taptite fastener and tighten.
5. Apply petroleum jelly or dielectric grease to battery cable ends and terminals.
6. Connect positive (+) cable first, then negative (-) cable.
7. Tip seat back (see *TIPPING SEAT FORWARD* on page 20).

### Cleaning Battery and Battery Cables

Figure 19

1. Tip seat forward (see *TIPPING SEAT FORWARD* on page 20).
2. Disconnect negative (-) cable first, then positive (+) cable.
3. Clean battery cable ends, negative (-) terminal, and positive (+) terminal with a wire brush and rinse with a weak baking soda solution.
4. Apply petroleum jelly or dielectric grease to battery cable ends and terminals.
5. Connect positive (+) cable first, then negative (-) cable.
6. Tip seat back (see *TIPPING SEAT FORWARD* on page 20).

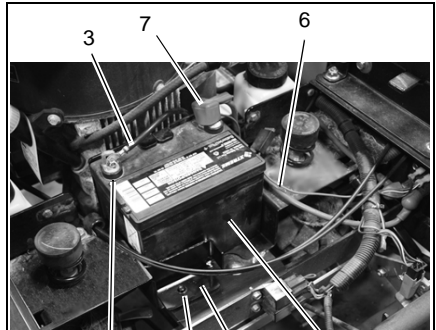

1. Battery Bracket
2. Taptite Fastener
3. Negative (-) Cable
4. Negative (-) Terminal
5. Battery
6. Positive (+) Cable
7. Positive (+) Terminal

Figure 19

## Charging the Battery

Figure 19

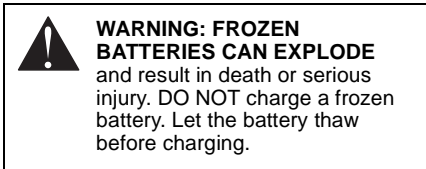

Follow First Aid directions for contact with battery fluid.

- External Contact: Flush with water.
- Eyes: Flush with water for at least 15 minutes and get medical attention immediately!
- Internal Contact: Drink large quantities of water. Follow with Milk of Magnesia, beaten egg or vegetable oil. Get medical attention immediately!
- In case of internal contact, **DO NOT** induce vomiting!

**IMPORTANT:** **DO NOT** fast charge. Charging at a higher rate will damage or destroy battery.

**IMPORTANT:** ALWAYS follow information provided on battery and battery charger. Contact battery and battery charger manufacturers for detailed instructions.

1. Remove battery from unit (see *Battery Removal and Installation* on page 23).
2. Place battery in a well-ventilated area.
3. Connect positive (+) lead of charger to positive (+) terminal, and negative (-) lead of charger to negative (-) terminal.
4. Charge battery according to battery charger and battery manufacturers' instructions.
5. Install battery on unit (see *Battery Removal and Installation* on page 23).

## Jump-Starting

Ariens does not recommend jump-starting your unit. Jump-starting can damage engine and electrical system components. See your engine manual for more detailed information.

## ADJUSTING STEERING LEVERS

Figure 20

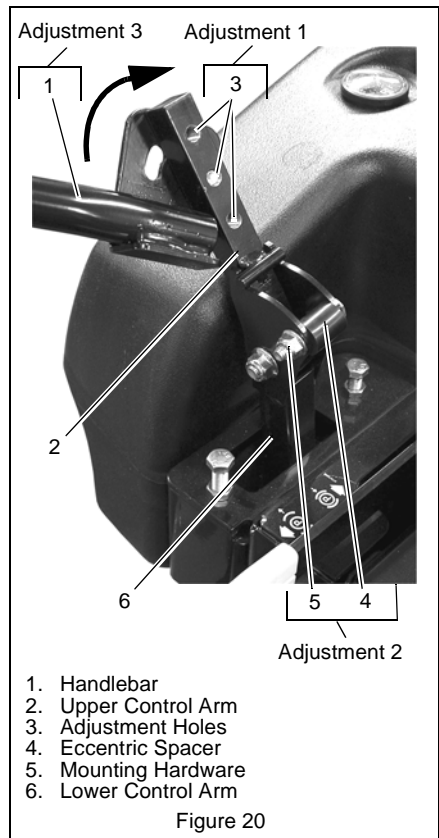

**IMPORTANT:** Adjust each steering lever equally.

**NOTICE:** When adjusting steering levers for the first time it is recommended that you make adjustments in the following order.

### 1. Adjust Steering Lever Height

1. Remove mounting hardware that attaches the handlebars to the upper control arm. Move handlebar up or down until the handlebar mounting holes are aligned with the preferred adjustment holes.
2. Install mounting hardware and tighten.

### 2. Adjust Steering Lever Width

1. Loosen hardware at the base of the lower control arm item 5.
2. Rotate eccentric spacer to move the levers away from or closer to the operators position (figure 21).



### Eccentric Spacer

Rotate this end away from the operator position to move the steering levers in.

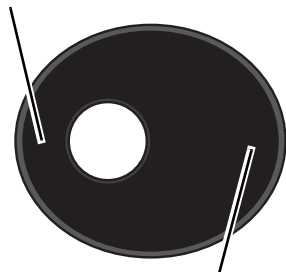

Rotate this end away from the operator position to move the steering levers out.

Figure 21

### 3. Adjust Steering Lever Forward or Backward

1. Loosen, do not remove, the bolts securing the handlebar to the upper control arm.
2. Slide steering lever forward or backward to desired position and tighten bolts.

**NOTICE:** Tighten upper bolt first.

### Forward and Reverse Speed Adjustment

Figure 22

**IMPORTANT:** The unit should track within 2' (0.610 m) of a straight line for 30' (9.14m).

The travel of the steering levers may need adjustment if:

- The unit turns to the right or left when both steering levers are pushed as far forward as possible.
- The unit turns to the right or left when both steering levers are pulled back as far rearward as possible.

**NOTICE:** The side the unit turns toward indicates that the wheel on that side is turning slower than the other wheel. Either the wheel that is turning faster needs to slow down or the wheel that is turning slower needs to be sped up to allow the unit to travel in a straight line.

1. Determine which way the unit turns.

**NOTICE:** The forward travel adjustment bolt adjusts the rear travel of the steering lever. The rear travel adjustment bolt adjusts the forward travel of the steering lever.

2. Adjust speed by loosening jam nut and:

- Turning adjustment bolt clockwise to decrease steering lever travel.
- Turning adjustment bolt counter clockwise to increase steering lever travel.

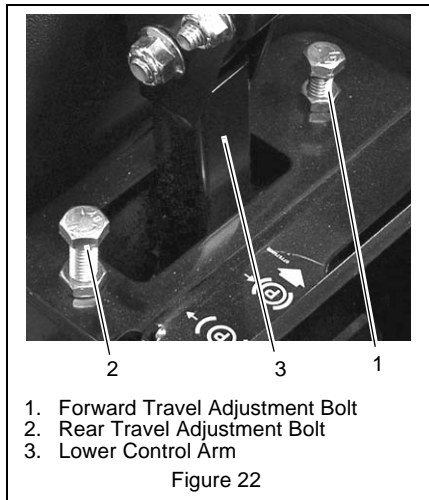

### REPLACING PTO BELT

#### Remove

Figure 23

1. Lower mower deck to the ground.
2. Remove belt covers from mower deck.



**CAUTION:** Use care when releasing idler spring tension. Keep body parts well away from idler when performing this operation.

3. Hook a puller into idler hole and pull idler arm towards outside of unit until tension is removed from PTO belt.

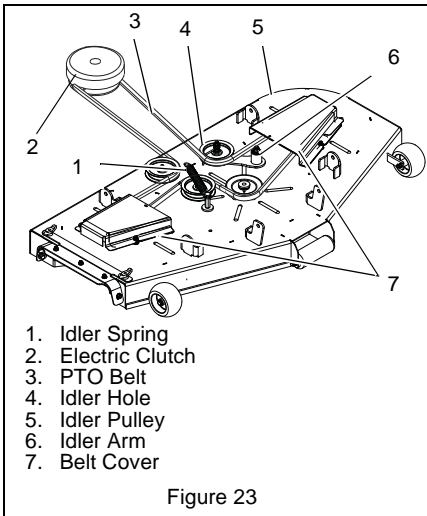

Figure 23

4. Remove PTO belt from left mower deck pulley.
5. Slowly release idler arm until tension is removed from idler spring.
6. Remove PTO belt from mower deck and electric clutch.

### Install

Figure 23

**NOTICE:** Do not install PTO belt on left mower deck pulley in step 1.

1. Install PTO belt on electric clutch and mower deck.
2. Hook a puller into idler hole and pull idler arm towards outside of unit until PTO belt can be routed around left mower deck pulley.
3. Slowly release idler arm until idler pulley rests firmly against PTO belt.
4. Install belt covers on mower deck.

## REPLACING HYDROSTATIC BELT

### Remove

Figure 24

1. Remove PTO belt (see *REPLACING PTO BELT* on page 25).
2. Disconnect electric clutch connector.
3. Remove clutch stop.



**CAUTION:** Use care when releasing idler spring tension. Keep body parts well away from idler when performing this operation.

4. Disconnect idler spring.
5. Remove hydrostatic belt from hydrostatic transmission pulleys, pulley, electric clutch, and idler.

### Install

Figure 24

1. Install hydrostatic belt on idler, electric clutch, pulley, and hydrostatic transmission pulleys.
2. Connect idler spring.
3. Install clutch stop.
4. Connect electric clutch connector.
5. Install PTO belt (see *REPLACING PTO BELT* on page 25).

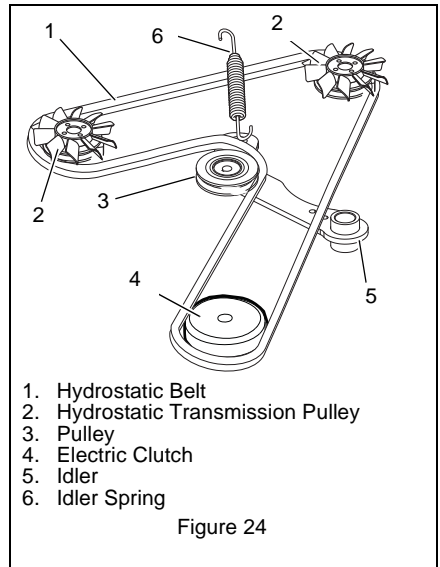

Figure 24

### Check Hydraulic Fluid Level

Figure 25

Check the system with the unit cold and parked on a flat, level surface.

Then run the unit for about one minute and recheck the levels.

### To Add Hydraulic Fluid:

Figure 25

1. Remove the cap from the expansion tank.
2. Fill the expansion tank with 20W-50 engine oil with an SL API classification until oil level reaches the cold fill line on the tank.

3. Install the expansion tank cap and then purge the system. See "Purging the Hydraulic System" on page 27.

The hydraulic fluid should be at the cold fill line of the expansion tank.

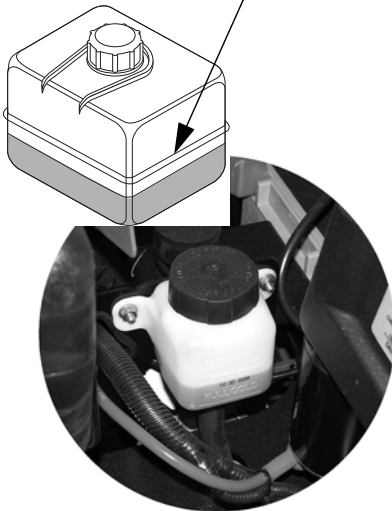

Figure 25

## Change Hydraulic Fluid and Filter

Figure 26

**NOTICE:** Change hydraulic fluid and filter after the first 75 hours of operation and then every 400 hours. Use 20W-50 engine oil with an SL API classification.

1. Place container under oil filter to catch oil.
2. Remove the filter guard and oil filter from the transaxle.
3. Remove the oil drain plug or fitting from the inlet port and allow the transaxle to drain completely.
4. Clean the filter mounting surface and then lubricate rubber gasket on new oil filter with clean hydraulic oil.
5. Spin new oil filter onto filter housing until it makes contact. Tighten oil filter another 3/4 turn.
6. Install the filter guards removed in step 2. Tighten the mounting screws to 5.38 lbf-ft (7.3 N•m).
7. Fill with 20W-50 engine oil with an SL API classification until oil appears at the bottom of the drain plug (about 2 quarts per transaxle). Install the drain plug and tighten it to 14.97 lbf-ft (20.3 N•m).
8. Repeat steps 1 – 7 for the other transaxle.

9. Follow the instructions in "To Add Hydraulic Fluid:" on page 26.

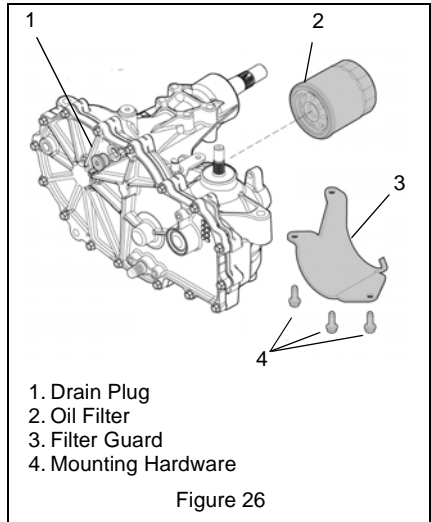

## Purging the Hydraulic System



**WARNING:** This adjustment requires operating the engine. Use extreme care to avoid contact with moving parts and hot surfaces. Be sure rear of unit is well supported and secure before starting engine.

1. With the unit up to and facing a wall, jack up the unit so that both drive wheels are off the ground.
2. Disengage the parking brake and put the transaxle bypass levers in the neutral position (see *MOVING UNIT MANUALLY* on page 17).
3. Start the engine and slowly move the steering levers in forward and reverse five or six times.
4. Stop the engine and put the transaxle bypass levers in the drive position (see *MOVING UNIT MANUALLY* on page 17).
5. Start the engine and slowly move the steering levers in forward and reverse five or six times.
6. Stop the engine, check the oil level and add oil as needed.
7. Repeat steps 2 – 6 until the transaxles operate smoothly in forward and reverse at normal speeds without excessive noise.

# STORAGE

## Short Term Storage

**IMPORTANT:** NEVER clean unit with high-pressure water or store unit outdoors.

Remove all dirt, grease, leaves, etc. Store in a clean dry area.

Inspect unit for signs of wear or damage.

Ensure all fasteners are properly tightened.

## Long Term Storage

Follow all instructions under *Short Term Storage*.

Remove and fully charge battery. Store in a clean dry area.

Refer to Engine Manual for the proper engine storage procedures.

Touch up all scratched or chipped paint surfaces.

## Fuel System

Gasoline left in the fuel system for extended periods without a stabilizer will deteriorate, resulting in gum deposits in the system.

These deposits can damage the carburetor and the fuel hoses, filter and tank. Prevent deposits from forming in the fuel system during storage by adding a quality fuel stabilizer to the fuel. Follow the recommended mix ratio found on the fuel stabilizer container.

**IMPORTANT:** NEVER store the engine with fuel in the fuel tank inside of a building with potential sources of ignition.

## Add Fuel Stabilizer

1. Turn the fuel valve off while engine is running and allow the engine to run until it stops. Turn engine OFF when it begins surging to avoid engine damage.
2. Add fuel stabilizer, following the manufacturer's instructions.
3. Turn fuel valve on after adding fuel stabilizer.
4. Re-start engine.
5. Run the engine outdoors for 1 minute to be sure that treated gasoline has replaced the untreated gasoline in the carburetor.
6. Slow the engine to an idle speed.
7. Stop engine.

# TROUBLESHOOTING

PROBLEM	PROBABLE CAUSE	CORRECTION
<b>Engine will not crank/start.</b>	<ol style="list-style-type: none"> <li>1. Safety interlock system is not engaged or is faulty.</li> <li>2. Fuel tanks empty.</li> <li>3. Discharged battery.</li> <li>4. Poor connection between battery and battery cables.</li> <li>5. Spark plug wire(s) loose or spark plug(s) faulty.</li> <li>6. Faulty electrical system.</li> <li>7. Faulty engine.</li> </ol>	<ol style="list-style-type: none"> <li>1. Check safety interlock system (see <i>Safety Interlock System</i> on page 14).</li> <li>2. Fill fuel tanks (see <i>FILLING FUEL TANK</i> on page 16).</li> <li>3. Charge battery (see <i>Charging the Battery</i> on page 24).</li> <li>4. Tighten battery cables and/or clean battery and battery cables (see <i>Cleaning Battery and Battery Cables</i> on page 23).</li> <li>5. Connect spark plug wire(s) or replace spark plug(s). Refer to Engine Manual for detailed instructions.</li> <li>6. Contact your Ariens Dealer.</li> <li>7. Contact your Ariens Dealer.</li> </ol>
<b>Engine runs rough.</b>	<ol style="list-style-type: none"> <li>1. Choke engaged.</li> <li>2. Air filter cartridge plugged.</li> <li>3. Faulty engine.</li> </ol>	<ol style="list-style-type: none"> <li>1. Disengage choke.</li> <li>2. Clean or replace air filter cartridge. Refer to Engine Manual for detailed instructions.</li> <li>3. Contact your Ariens Dealer.</li> </ol>
<b>Unit does not move with engine running when using steering levers.</b>	<ol style="list-style-type: none"> <li>1. The transmission bypass lever is engaged.</li> <li>2. Faulty hydrostatic belt.</li> <li>3. Faulty transmission.</li> </ol>	<ol style="list-style-type: none"> <li>1. Disengage transmission bypass lever (see on page 18).</li> <li>2. Replace hydrostatic belt (see <i>REPLACING HYDROSTATIC BELT</i> on page 26).</li> <li>3. Contact your Ariens Dealer.</li> </ol>
<b>PTO or mower blades do not engage or shuts off.</b>	<ol style="list-style-type: none"> <li>1. Operator presence switch not depressed.</li> <li>2. Faulty operator presence switch.</li> <li>3. Electric clutch connector is loose or disconnected.</li> <li>4. Faulty PTO belt.</li> <li>5. Faulty PTO switch, wires, connectors, or clutch.</li> </ol>	<ol style="list-style-type: none"> <li>1. Depress operator presence switch by sitting on seat.</li> <li>2. Contact your Ariens Dealer.</li> <li>3. Connect the electric clutch connector. See <i>REPLACING HYDROSTATIC BELT</i> on page 26 for the electric clutch connector location.</li> <li>4. Replace PTO belt (see <i>REPLACING PTO BELT</i> on page 25).</li> <li>5. Contact your Ariens Dealer.</li> </ol>

<b>PROBLEM</b>	<b>PROBABLE CAUSE</b>	<b>CORRECTION</b>
<b>Engine overheats.</b>	<ol style="list-style-type: none"> <li>1. Engine oil level low.</li> <li>2. Cooling system plugged.</li> <li>3. Faulty engine.</li> </ol>	<ol style="list-style-type: none"> <li>1. Add engine oil. Refer to Engine Manual for detailed instructions.</li> <li>2. Clean cooling system. Refer to Engine Manual for detailed instructions.</li> <li>3. Contact your Ariens Dealer.</li> </ol>
<b>Unit moves with engine off and parking brake engaged.</b>	<ol style="list-style-type: none"> <li>1. The parking brake needs adjustment.</li> <li>2. Faulty parking brake.</li> </ol>	<ol style="list-style-type: none"> <li>1. Contact your Ariens Dealer.</li> <li>2. Contact your Ariens Dealer.</li> </ol>
<b>Hour meter continues when engine not running.</b>	<ol style="list-style-type: none"> <li>1. Ignition key is in the run position with engine turned off.</li> </ol>	<ol style="list-style-type: none"> <li>1. Turn ignition key to the off position.</li> </ol>
<b>Unit does not travel in a straight line.</b>	<ol style="list-style-type: none"> <li>1. Incorrect tire pressure.</li> <li>2. Steering levers need adjustment.</li> <li>3. Hydrostatic transmission and/or linkage needs adjustment.</li> </ol>	<ol style="list-style-type: none"> <li>1. Check tire pressure (see <i>Specifications</i> on page 32)</li> <li>2. Adjust steering levers (see <i>Forward and Reverse Speed Adjustment</i> on page 25)</li> <li>3. Contact your Ariens Dealer.</li> </ol>
<b>Unit creeps with steering levers in neutral position.</b>	<ol style="list-style-type: none"> <li>1. Hydrostatic transmission and/or linkage needs adjustment.</li> </ol>	<ol style="list-style-type: none"> <li>1. Contact your Ariens Dealer.</li> </ol>
<b>Poor cutting quality.</b>	<ol style="list-style-type: none"> <li>1. Mower deck not level or mower pitch is incorrect.</li> <li>2. Dull or faulty mower blades.</li> </ol>	<ol style="list-style-type: none"> <li>1. Level and adjust pitch of mower deck (see <i>The Distance From The Mower Blades To The Ground</i> on page 21).</li> <li>2. Sharpen mower blades or replace mower blades (see <i>REPLACING MOWER BLADE</i> on page 20).</li> </ol>

## ACCESSORIES

See your authorized Ariens dealer to add these optional accessories to your unit.

Part No.	Description
71502900	Dump Cart
71509000	42" Mulch Kit
71508700	48" Mulch Kit
71509100	54" Mulch Kit
71503200	48" Aerator
71503300	36" Roller
71503400	48" Dethatcher
71510300	15 – Gallon Sprayer
71503600	Spreader
71509200	Sunshade
81502200	3 – Bag Powered Bagger (SN 000101 – 029999)
81515400	Bagger Kit
71509300	Trailer Hitch
51526000	Deck Kit CE
71509400	Light Kit
71513300	XL – 42" Blow Out Baffle Kit

## SERVICE PARTS

Be sure to always use genuine Ariens parts to keep your unit running like new.

Part No.	Description
21541700	Spark Plug
21541500	Fuel Filter
21550700	Air Filter
21550800	Engine Oil Filter
21545100	Hydraulic Oil Filter
02961600	42" Mower Blade
03288600	42" Mulching Blade
02982000	48" Mower Blade
00273000	48" Mulching Blade
02961700	54" Mower Blade
03288700	54" Mulching Blade
07242200	Hydrostatic Belt
07200037	42" PTO Belt
07200436	48" PTO Belt
07200023	54" PTO Belt

## SPECIFICATIONS

<b>Model Number</b>	915163	915165	915173
<b>Model</b>	Zoom XL 42	Zoom XL 48	Zoom XL 54
<b>Engine</b>	Kohler	Kohler	Kohler
Displacement – in. <sup>3</sup> (cc)	44.2 (725)		
Max Governed RPM (May be different from maximum RPM)	3600 ± 0 - 100		
<b>Speed</b>			
Forward Max. – m.p.h. (km/h)	6.5 (10.46)		
Reverse Max. – m.p.h. (km/h)	3 (3.2)		
<b>Turning Radius</b>	Zero		
<b>Brakes</b>	Internal Transmission		
<b>Electrical</b>			
Starter	Electric		
Battery	12 Volt Maintenance Free		
PTO (Power Take Off)	Electric Clutch/Brake		
<b>Fuel</b>			
Fuel Type	Refer to Engine Manual		
Fuel Tank Capacity – gal. (L)	4.5 (17.0)		
<b>Transmission</b>	Hydrostatic Drive		
<b>Size and Weight</b>			
Length – in. (cm)	69 (175.3)		
Width – in. (cm)	52 (132.1)	58 (124.5)	56 (147.3)
Weight – lbs. (kg)	615 (279.5)	630 (286.4)	645 (293.2)
Height – in. (cm)	42 (106.7)		
<b>Tires</b>			
Front Tire Size – in.	11 x 4		
Rear Tire Size – in.	20 x 8	20 x 10	
Front Tire Pressure – psi (kPa)	46 (317)		
Rear Tire Pressure – psi (kPa)	10 (69)		
<b>Mower Deck</b>			
Cutting Height – in. (cm)	1.5 – 4.5 (3.81 – 11.4)		
Cutting Width – in. (cm)	42 (107)	48 (122)	54 (137)
<b>Max. Towing Capacity – lbs. (kg)</b>	300 (136)		
<b>Max. Tongue Weight – lbs. (kg)</b>	30 (13.6)		





# Consumer Mowing Equipment Limited Warranty

Ariens Company (Ariens) warrants to the **original purchaser** that Ariens, Gravely and Countax brand lawn and garden consumer products purchased on or after 1/1/2012 will be free from defects in material and workmanship for the time period noted in the chart below. Equipment put to personal use around a single household or residence is considered "Consumer Use"; equipment put to any business use (agricultural, commercial, or industrial) or used at multiple locations is considered "Commercial Use." If any product is rented or leased, then the duration of these warranties shall be 90 days after the date of purchase.

An authorized Ariens dealer (Ariens brand products), Gravely dealer (Gravely brand products), or Countax dealer (Countax brand products) will repair any defect in material or workmanship, and repair or replace any defective part, subject to the conditions, limitations and exclusions set forth herein. Such repair or replacement will be free of charge (labor and parts) to the original purchaser except as noted below.

Warranty Code	Product Group	Warranty Period Consumer Use	Warranty Period Commercial Use
HA	Zoom & ZT Zero-Turn Riders; AMP™ Rider	3 Years	90 Days
HB	Max Zoom & ZT HD Zero-Turn Riders	3 Years	1 Year
HC	Tractors, "961" Series Walk-Behind Mowers	2 Years	90 Days
HD	Classic LM Series Mowers; Wide Area Walk Mowers	3 Years	90 Days
N/A	Service (replacement) Parts	90 Days (no labor)	90 Days (no labor)

### Special Extensions

The chart below details special extensions to this warranty:

Warranty Code	Warranty Exception	Warranty Period	Use	Detail
HA, HB	Mower Deck Shell on Zero-Turn Riders	5 Years	Consumer	3 years parts and labor Additional 2 years parts only
HA, HB	Main Frame on Zero-Turn Riders	5 Years	Consumer	3 years parts and labor Additional 2 years parts only
HA	Batteries for AMP™ Rider	2 Years	Consumer	100% first year; prorated second year

### Exceptions and Limitations

The chart below details special exceptions to this warranty:

Warranty Code	Warranty Exception	Warranty Period	Use	Detail
All	Batteries	1 Year	Consumer	Prorated
All	Belts, Muffler, Tires	None	Commercial	These components are not covered when used commercially.
All	Cloth, Plastic, and Rubber Components (Including Belts and Cables)	Maximum 2 Years	All	Warranty is limited to 2 years for consumer use. Except as noted above, these components are covered for defect, not for wear.
All	Engines	See Engine Manufacturer's Warranty	All	Engines are covered by engine manufacturer's warranty. Refer to engine manufacturer's warranty statement.

### Customer Responsibilities

**Register the product immediately at the time of sale.** If the dealer does not register the product, the customer must complete the product registration card in the literature package and return it to the Ariens Company, or register the unit online at [www.ariens.com](http://www.ariens.com), [www.gravely.com](http://www.gravely.com), [www.countax.com](http://www.countax.com).

To obtain warranty service, the **original purchaser** must:

- Perform the maintenance and adjustments explained in the owner's manual.
- Promptly notify Ariens or an authorized Ariens, Gravelly or Countax service representative of the need for warranty service.
- Transport the product to and from the place of warranty service at owner's expense.
- Have the warranty service performed by an authorized Ariens, Gravelly or Countax service representative.

**To Find an Authorized Service Representative:**

<b>In the U.S. and Canada:</b>		
Use the dealer locator on our websites: <a href="http://www.ariens.com">www.ariens.com</a> • <a href="http://www.gravelly.com">www.gravelly.com</a>		
Or contact us by mail or by phone:		
<b>In the U.S., Canada, Mexico, Caribbean, Central and South America:</b>	<b>In Europe, Asia, Africa or the Middle East:</b>	<b>In Australia or New Zealand:</b>
Ariens Company 655 W. Ryan Street Brillion, WI 54110 Phone: (920) 756 - 4688 <a href="http://www.ariens.com">www.ariens.com</a>	Countax Ltd, Countax House Great Haseley, Oxfordshire, OX44 7PF Phone: 0800 597 7777 <a href="http://www.countax.com">www.countax.com</a>	Ariens Company Building 2 6 Wedgewood Rd. Hallam, Victoria 3803 Australia Phone: (03) 9796 4244 1800 335 489 <a href="http://www.ariens.com.au">www.ariens.com.au</a>

**Exclusions – Items Not Covered by This Warranty**

- Parts that are not genuine Ariens, Gravelly or Countax service parts are not covered by this warranty and may void the warranty.
- Damages resulting from the installation or use of any part, accessory, or attachment which is not approved by the Ariens Company for use with product(s) identified herein are not covered by this warranty.
- The following maintenance, service and replacement items are not covered by this warranty unless they are noted in the Limitations section above: lubricants, spark plugs, oil, oil filters, air filters, fuel filters, brake linings, brake arms, brake shoes, skid shoes, scraper blades, shear bolts, mower blades, mower vanes, brushes, headlights, light bulbs, knives, cutters.
- Any misuse, alteration, improper assembly, improper adjustment, neglect, or accident which requires repair is not covered by this warranty.
- **Use of gasoline blends exceeding 10% ethanol voids any and all warranties.**
- Products are designed to the specifications in the area that the product was originally distributed. Different areas may have significantly different legal and design requirements. This warranty is limited to the requirements in the area in which the unit was originally distributed. Ariens Company does not warrant this product to the requirements of any other area. Warranty service is limited to service within the area originally distributed.
- In countries other than the United States and Canada, contact the Ariens Company dealer for warranty policies that govern within your country. Rights may vary from country to country and within any one country.

**Disclaimer**

Ariens Company may from time to time change the design of its products. Nothing contained in this warranty shall be construed as obligating the Ariens Company to incorporate such design changes into previously manufactured products, nor shall such changes be construed as an admission that previous designs were defective.

**LIMITATION OF REMEDY AND DAMAGES**

Ariens Company's liability under this warranty, and under any implied warranty that may exist, is limited to repair of any defect in workmanship, and repair or replacement of any defective part. Ariens Company shall not be liable for incidental, special, or consequential damages (including lost profits). Some states do not allow the exclusion of incidental or consequential damages, so the above limitation or exclusion may not apply to you.

**AUSTRALIAN CONSUMER LAW**

The following applies solely to warranties subject to Subsection 102(1) of the Australian Consumer Law: Our goods come with guarantees that cannot be excluded by the Australian Consumer Law. You are entitled to a replacement or refund for a major failure and for compensation for any other reasonably foreseeable loss or damage. You are also entitled to have the goods repaired or replaced if the goods fail to be of acceptable quality and failure does not amount to a major failure.

**DISCLAIMER OF FURTHER WARRANTY**

Ariens Company makes no warranty, express or implied, other than what is expressly made in this warranty. If the law of your state provides that an implied warranty of merchantability, or an implied warranty of fitness for particular purpose, or any other implied warranty, applies to Ariens Company, then any such implied warranty is limited to the duration of this warranty. Some states do not allow limitations on how long an implied warranty lasts, so the above limitation may not apply to you.

*This warranty gives you specific legal rights, and you may also have other rights which vary from region to region.*





Ariens  
655 West Ryan Street  
Brillion, WI 54110  
920-756-4688  
Fax 920-756-2407  
[www.ariens.com](http://www.ariens.com)



## **WARNING**



The engine exhaust from this product contains chemicals known to the State of California to cause cancer, birth defects or other reproductive harm.

An *Ariens* Company Brand