



USE AND MAINTENANCE LIGHT TOWER



General Safety Information

Allowed use

The light tower has been designed to lighten the area in which it is positioned and oriented, after installing it on a generating set foreseen for this purpose. The generator supplies the electrical feeding necessary to operate the light tower.

Any other use is expressly forbidden and could generate risks to the user's safety and damages to the product.

Improper use

As improper use, it is meant any use different from the ones allowed (for which the lighting tower has been designed) or with unforeseen or expressly forbidden procedures.



When in operating configurations, the generator and tower light assembly has to be positioned on a field with slope not higher than 8%.



The use of the light tower is forbidden if the environmental conditions do not correspond to the ones indicated.

Precautions during the installation

It is necessary to know the dimensions of the assembly represented by the generator and the light tower, in all the foreseen configurations, in order to set the correct distance from each possible obstacle and estimate the right spaces to carry the installation operations on.

It is requested to examine the features of the area in which operate as the working surface has to be flat and compact.



The working area has to be kept in order, avoiding that items of any sort compels or make it difficult to the personnel, the generator and the lighting tower, any kind of movements.



Before changing the position of the lighting tower or lifting the telescopic mast, please make sure that anyone, objects and/or animals are in the proximity of the working area.



Before moving the lighting tower or lifting the telescopic mast, please make sure that no power lines are in the proximity of the working area. The contact of the light tower with live electrical cables can result in serious injury to the personnel or cause immediate death by electrocution.

Working precautions

Before operating the generating set and, as a consequence, use the lighting tower, please carry the following preliminary controls out:

- The installation and the mounting have to be carried out properly, in the strict respect of all the directions given in this manual.
- All the parts of the generator and the light tower have to be in good conditions and regularly submitted to the foreseen periodical maintenance.
- Unauthorized persons, objects and/or animals cannot be admitted to or interfere with the generator and the light tower.



The contact with the power lines can cause serious injury to the personnel or lead to immediate death by electrocution.



The contact with hot surfaces (floodlights) can cause burns.

During the operation of the generator and the lighting tower, please pay attention to possible wind-speed increasing or to the approaching of strong storms.

The maximum allowed wind-speed cannot exceed 110 Km/h.



Do not operate or move the lighting tower when the generating set is working.



The maximum payload of the telescopic mast is 12 Kgs
The maximum allowed wind-speed cannot exceed 110 Km/h.

The improper use of this product is greatly dangerous. The manufacturer declines any responsibility for damages to persons, objects and/or animals, deriving from an improper use of the product.

Technical features of the lighting tower

The pneumatic telescopic mast on which the lighting system is positioned, allow to lift the lighting point to several metres from the ground.

The telescopic mast is made of sections which can be manually locked.

The locking operations of the sections is always recommended as it reduces the pneumatic pressure load during the operations, protecting the internal sealing gaskets.

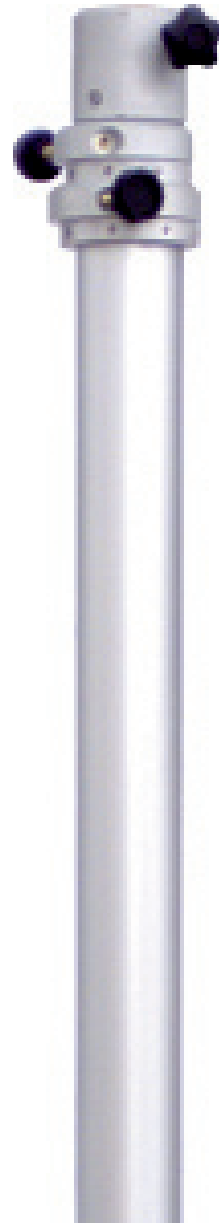

Models of Lighting Towers

Lighting tower integrated in the generating set

The lighting tower is located and positioned horizontally on the upper part of the generating set.

For the operation of the telescopic mast, the system foresees a simple procedure of manual lifting of the mast/floodlights assembly. By acting on the locking handle, it is possible to rotate the lighting tower from the horizontal to the vertical position for its normal working.

TRASNPOT KIT NOT INCLUDED



Lighting Tower separated from the generating set.

The separated lighting tower, allow to position the telescopic mast independent from the generating set. In this case the telescopic mast will be used with a support tripod of easy and quick setting.



Installation and mounting

Fix the lighting tower bracket on the generator by means of U bolts, after adjusting the two telescopic brackets to the dimensions of the gen-set; then place the lifting plates between the two components.

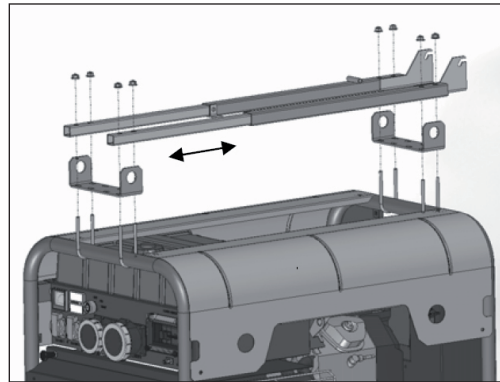

Assembly the bearing collar on the mast body. The fixing position may vary and depends on the generating set in your hands, in order to grant a safe grip of the support feet to the ground.

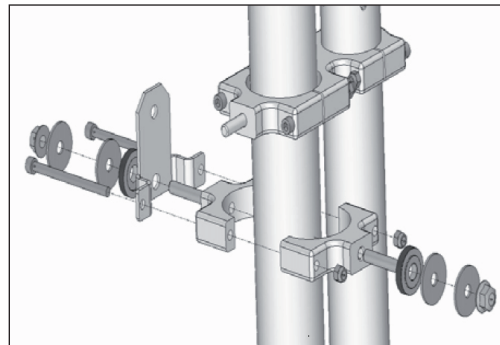

NOTE

Please respect the order of the components as in the figure

Installation and mounting

Combine the mast complete with collar to the fixed support by positioning it in the relevant bearing loops, and fastening it by the nuts at the ends. Fix the locking tie rod with the pin and the handle

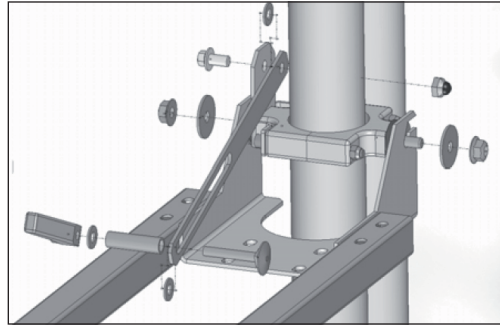

DANGER

Avoid to position the stabilizers on holes or hollow of the ground as the generator and the lighting tower can be instable, with consequent risk of overturning. In case it is necessary, correct the position of the generator so that the stabilizers lay effectively on the ground. The new position will have to be ideal for ensuring the lighting tower stability.

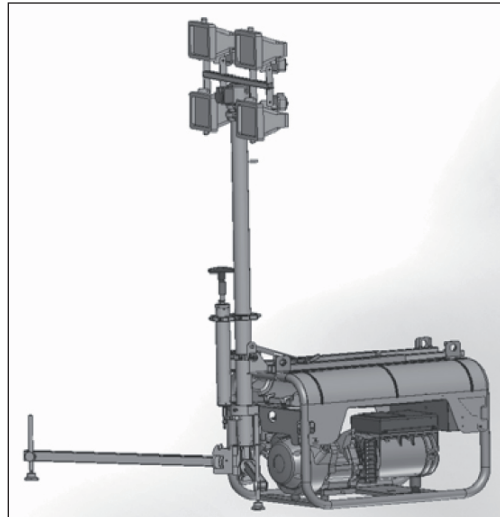

Setting the Lighting Tower

Lighting Tower integrated in the generating set

1) By acting on the locking handle, it is possible to rotate the lighting tower from the horizontal to the vertical position. Lower the stabilizing brackets by positioning them onto the floor.



2) Place on the mast head and fasten by the relevant hand-wheel, the floodlight unit.

ATTENTION: PLEASE CHECK IF THE LOCKING THROUGH THE PROPER HANDLE HAS BEEN CARRIED OUT CORRECTLY.



3) By acting on the hand-pump placed at base, the extension sequence of the telescopic mast will start. It is possible to place the lamp unit at the desired height.

4) Put the fuel valve “F” to the “ON” open position, then the gen-set is ready for ignition.

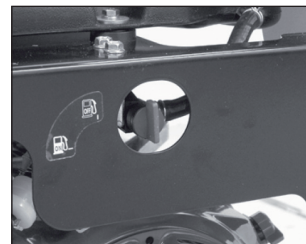

NOTE

To keep the working life of the pneumatic circuit, it is recommended the manual locking of the sections by the relevant hand-wheel.

Lighting Tower separated from the generating set

The lighting tower complete with tripod is independent and is supplied separately from the generating set. The mast and its lamp unit can be positioned separately.



The operating instructions of this system are the same; it is however requested special attention when placing the unit on the ground and when adjusting the stabilizing brackets.



Carefully adjust the stabilizers and make sure the lighting tower group is firmly standing on the floor.

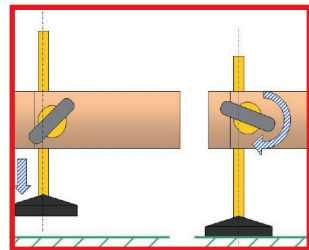

NOTE

When operating the lighting tower (Lighting tower ON and oriented) a contemporarily use of the generator to feed other machines or equipment is allowed, according to the limitations and the performances foreseen in the use and maintenance manual of the generating set.

Switching the floodlights on

- 1) Start the generator
- 2) Wait for some seconds from the starting and put the lighting tower plug into the gen-set socket.



If using a generator with manual rope-pull starting N (image 41) use the protection gloves to avoid injuries to the hands whilst releasing the recoil rope.



When in use, the floodlights reach high temperatures and may cause contact burns. Adjust the directing by using the proper working gloves or wait for the complete cooling.

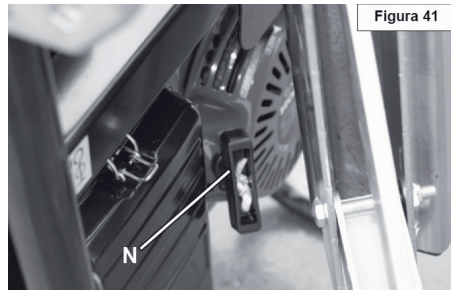

NOTE

When the lighting tower is not in use, it has to be brought back to the parking configuration.

Bring the light tower to its restore position

Follow the below mentioned procedures to bring the light tower back to its restore position:

- Switch the floodlights off and disconnect the electrical power
- Lower the mast by opening the discharge valve placed at the pump or at the mast base (make sure to unlock the sections by releasing the clamps)
- Unblock and remove the lamp unit from the mast head
- Lift the stabilizers and put the mast in its housing

Parking and Transporting

Lifting instructions:

The lighting tower bracket has 4 lifting points



The lifting kit has been designed for an exclusive use on the Pramac's units, where the use of a lighting tower is foreseen.



Lift the generator only when the lighting tower has been removed from its support or blocked in the horizontal position and with the stabilizers closed.

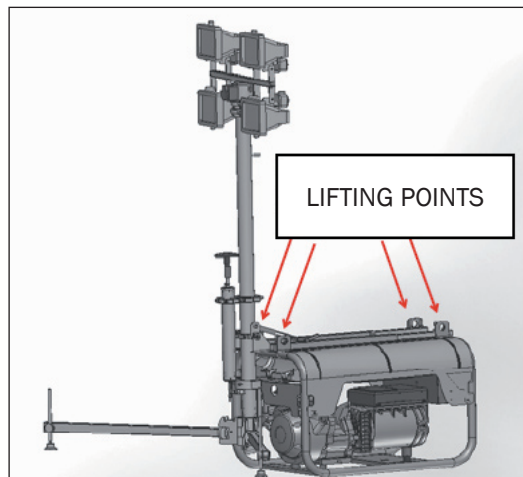

TROUBLESHOOTING

When pumping, the mast does not extend or extends partially

1. Obstruction or throttling of the pneumatic hose from the pump or from an external source to the mast

Proceed by cleaning, dismantling and with the possible substitution with an equivalent spare part.

2. Pump inefficiency

Try the pump without the hose; make sure that the air release valve on the pump itself is open. If the pressure supplied is not enough, please do the maintenance by replacing the internal gaskets.

3. Check the air discharge valves are closed

Be sure that both (on the pump and on the mast base) are closed.

4. Lock the mast handles

Loosen all the handles to enable a smooth sliding

5. Check the status of the one-way valve

Check the valve (C) positioned on the pump outlet compels the pressure return. On the contrary, please replace the valve with a proper spare part.

6. Check the mast gasket

Once the leaking gasket has been detected, proceed dismantling the mast and replace it.

At the restore stage the mast does not retract completely

1. Handle locked

Loosen completely the handle which prevent from retracting

2. When temperature is quite low, it is possible to find ice inside the mast
Wait till a sufficient temperature increase and retract the mast completely

3. A gasket is blocked

Try to give pressure to the inlet to open the gasket

4. Mast buckling

Due to overload, to a damage generated by a hit or other, the mast cannot be completely retracted. It is necessary to dismantle it and proceed with an extra-ordinary maintenance to be carried out at the Manufacturer's premises.

The floodlights do not work

1. Loosening of the cabling clamp

Disconnect the electrical power, retract the mast and the status of the cabling.

2. Interruption of electrical cable

Disconnect the electrical power, retract the mast and, by means of a tester, make sure there is continuity in the circuits. If there is a disconnection, dismount the mast and send it to the Manufacturer for the replacement of the damaged cable.



PRAMAC S.p.a
Casole d'Elsa, Siena - Italy
info@pramac.com
Tel.: +39 0577 9651 Fax: +39 0577 949076