

MITSUBISHI GENERATOR

MODEL SERIES MGE1801/MGE2901/MGE4000/MGE4800
MGE5800/MGE6700

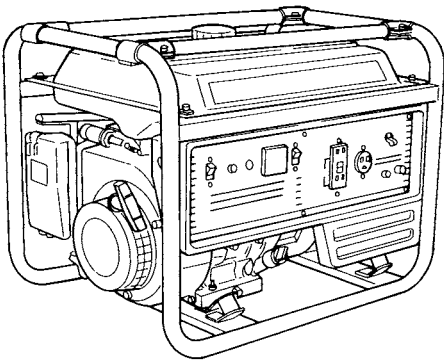

OWNER'S MANUAL

ENGLISH

MANUEL D'UTILISATION

FRANÇAIS

MANUAL DEL PROPIETARIO

ESPAÑOL

使用说明书

中文

**Before starting this generator,
read and understand this Owner's Manual.**

**Veillez lire et bien comprendre le manuel de
l'utilisateur avant de démarrer le générateur.**

**Antes arrancar este generador, lea y entienda
este Manual del propietario.**

**在起动本焊机/发电机之前，必须
熟读并理介本使用说明书。**



**MITSUBISHI
HEAVY INDUSTRIES, LTD.**

KN55060AA

CAUTIONARY NOTICE

The customer must know that the generator has potential danger.

MHI is not liable for any damage or injury arising from an individual's failure to follow instructions contained in this manual, or his failure to exercise due care and caution in the installation, operation, inspection, and service of the generator.

CONTENTS

	Page
1. SAFETY PRECAUTIONS.....	1
2. SPECIFICATIONS.....	2
3. COMPONENTS.....	5
4. PRE-OPERATION CHECKS.....	6
5. OPERATING PROCEDURES.....	9
6. SCOPE OF APPLICABILITY.....	16
7. MAINTENANCE SCHEDULE.....	17
8. "HOW-TO" MAINTENANCE.....	18
9. PREPARATION FOR STORAGE.....	21
10. TROUBLE SHOOTING.....	22
11. WIRING DIAGRAM.....	23
12. OPTIONAL PARTS.....	28

ENGL

(California, U.S.A.-Proposition 65 warning statement)



W A R N I N G

The engine exhaust from this product contains chemicals known to the State of California to cause cancer, birth defects or other reproductive harm.

Thank you for purchasing a Mitsubishi generator.

This manual covers operation and maintenance of the Mitsubishi generators. All information in this publication is based on the latest production information available at the time of approval for printing.

Pay special attention to statements preceded by the following words:

 **WARNING**

Indicates a strong possibility of severe personal injury, loss of life and equipment damage if instructions are not followed.

[CAUTION]

Indicates a possibility of personal injury, or equipment damage if instructions are not followed.

NOTE:









Gives helpful information.

If a problem should arise, or if you have any questions about the generator, consult a dealer selling Mitsubishi generator.

 **WARNING**

- **The generator is designed to give safe and dependable service if operated according to instructions.**
- **Do not operate the generator before you have read and understood the instructions. Failure to do so could result in personal injury or equipment damage.**

1. SAFETY PRECAUTIONS

-  Do not operate the generator near gasoline or gaseous fuel because of the potential danger of explosion or fire.
Do not fill the fuel tank with fuel while the engine is running. Do not smoke or use open flames near the fuel tank. Be careful not to spill fuel during refueling. If fuel is spilled, wipe it off and let it dry before starting the engine.
-  Do not place inflammables near the generator.
Be careful not to place fuel, matches, gunpowder, oily cloths, straw, trash, or any other inflammables near the generator.
-  Do not operate the generator inside a room, cave, tunnel, or other insufficiently ventilated area. Always operate it in a well-ventilated area, otherwise the engine may become overheated, and the poisonous carbon monoxide gas contained in the exhaust gases will endanger human lives. Keep the generator at least 1 meter (3 feet) away from any structure or building during use.
If the generator must be used indoors, the area must be well-ventilated and extreme caution must be taken regarding the discharge of exhaust gases.
-  Do not enclose the generator nor cover it with a box.
The generator has a built-in forced air cooling system, and may become overheated if it is enclosed.
-  Operate the generator on a level surface.
It is not necessary to prepare a special foundation for the generator. However, the generator will vibrate on an irregular surface, so choose a level place without surface irregularities. If the generator is tilted or moved during operation, fuel may spill and/or the generator may tip over, causing a hazardous situation.
Proper lubrication cannot be expected if the generator is operated on a steep incline or slope. In such a case, piston seizure may occur even if the oil is above the upper level.
-  Pay attention to the wiring from the generator to the connected device.
If the wire is under the generator or in contact with a vibrating part, it may break and possibly cause a fire or generator burnout.
-  Do not operate in rain or with wet hands.
The operator may suffer severe electric shock if the generator is wet due to rain or snow. If wet, wipe and dry it well before starting.
Do not pour water directly over the generator, not wash it with water.
-  Do not contact the generator to a commercial power line. Connection to a commercial power line may short circuit the generator and run it.
Use the transfer switch for connecting to domestic circuits.
-  No smoking while handling the battery.
The battery emits flammable hydrogen gas, which can explode if exposed to electric arcing or open flame.
Keep the area well-ventilated and keep open flames/sparks away when handling the battery.

2. SPECIFICATIONS

MODEL		MGE1801	MGE2901	
ALTERNATOR	Type	Brushless, Revolving Field, Self-exciting, 2-poles, Single phase		
	AC Voltage	50Hz	110V, 220V, 230V, 240V, 110V/220V	
		60Hz	110V, 120V, 220V, 240V, 110V/220V, 120V/240V	
	Max. Output	50Hz	1,500W	2,400W
		60Hz	1,800W	2,900W
	Rated Output	50Hz	1,200W	2,200W
		60Hz	1,500W	2,500W
	Voltage Regulator		Condenser Type, AVR Type (Option)	
	Power Factor		1.0	
DC Output		—	12V-8.3A (Option)	
ENGINE	Model	GM132PN	GM182PN	
	Type	Air-cooled, 4 cycle, OHV, Gasoline Engine		
	Displacement	126cm ³	181cm ³	
	Fuel	Regular Automobile Gasoline		
	Fuel Tank Capacity	14 L		
	Rated Continuous Operation	50Hz	15 h	10 h
		60Hz	14 h	8.5 h
	Lubricating Oil		Engine Oil SE Class or Higher	
	Lubricating Oil Capacity		0.6 L	0.6 L
Starting System		Recoil Starter		
DIMENSION	Length x Width x Height	564 x 422 x 440 mm		
	Dry Weight	42 kg	46 kg	

Specifications are subject to change without notice.

MODEL		MGE4000	MGE4800	
ALTERNATOR	Type	Brushless, Revolving Field, Self-exciting, 2-poles, Single phase		
	AC Voltage	50Hz	110V, 220V, 230V, 240V, 110V/220V	
		60Hz	110V, 120V, 220V, 240V, 110V/220V, 120V/240V	
	Max. Output	50Hz	3,500W	4,000W
		60Hz	4,000W	4,800W
	Rated Output	50Hz	2,800W	3,300W
		60Hz	3,300W	4,100W
	Voltage Regulator		Condenser Type, ATR Type (Option)	
Power Factor		1.0		
DC Output		12V-8.3A (Option)		
ENGINE	Model	GM291PN	GM301PN	
	Type	Air-cooled, 4 cycle, OHV, Gasoline Engine		
	Displacement	296cm ³	296cm ³	
	Fuel	Regular Automobile Gasoline		
	Fuel Tank Capacity	21 L		
	Rated Continuous Operation	50Hz	10 h	9.5 h
		60Hz	8.5 h	8 h
	Lubricating Oil	Engine Oil SE Class or Higher		
	Lubricating Oil Capacity	1.2 L		
	Starting System	Recoil Starter, Electric Starter (Option)		
DIMENSION	Length x Width x Height	628 x 495 x 495 mm		
	Dry Weight	68 kg	70 kg	

Specifications are subject to change without notice

MODEL		MGE5800	MGE6700	
ALTERNATOR	Type	Brushless, Revolving Field, Self-exciting, 2-poles, Single phase		
	AC Voltage	50Hz	110V, 220V, 230V, 240V, 110V/220V	
		60Hz	110V, 120V, 220V, 240V, 110V/220V, 120V/240V	
	Max. Output	50Hz	5,000W	5,700W
		60Hz	5,800W	6,700W
	Rated Output	50Hz	4,200W	5,100W
		60Hz	5,000W	5,800W
	Voltage Regulator		Condenser Type, AVR Type (Option)	
	Power Factor		1.0	
DC Output		12V-8.3A (Option)		
ENGINE	Model	GM401PN		
	Type	Air-cooled, 4 cycle, OHV, Gasoline Engine		
	Displacement	391cm ³		
	Fuel	Regular Automobile Gasoline		
	Fuel Tank Capacity	21 L		
	Rated Continuous Operation	50Hz	8.0 h	7.0 h
		60Hz	7.0 h	6.5 h
	Lubricating Oil	Engine Oil SE Class or Higher		
	Lubricating Oil Capacity	1.2 L		
Starting System	Recoil Starter, Electric Starter (Option)			
DIMENSION	Length x Width x Height	685 x 500 x 500 mm		
	Dry Weight	75 kg	78 kg	

Specifications are subject to change without notice.

3. COMPONENTS

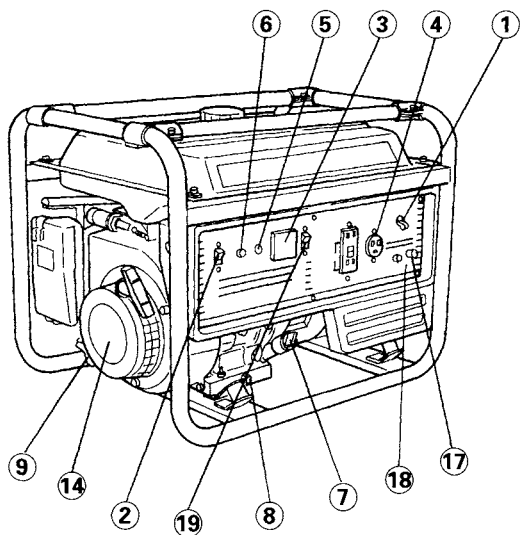

- ① AC NO-FUSE BREAKER
- ② ENGINE SWITCH
- ③ VOLTMETER
- ④ AC RECEPTACLE
- ⑤ PILOT LAMP
- ⑥ OIL WARNING LAMP (OPTION)
- ⑦ OIL FILTER CAP
- ⑧ OIL DRAIN PLUG
- ⑨ FUEL COCK
- ⑩ AIR CLEANER
- ⑪ SPARK PLUG
- ⑫ FUEL TANK CAP
- ⑬ CHOKE LEVER
- ⑭ RECOIL STARTER
- ⑮ GROUND TERMINAL
- ⑯ MUFLER
- ⑰ DC OUTPUT TERMINAL (OPTION)
- ⑱ DC CIRCUIT PROTECTOR (OPTION)
- ⑲ IDLE CONTROL SWITCH (OPTION)
- ⑳ FUEL GAUGE
- ㉑ FUEL TANK

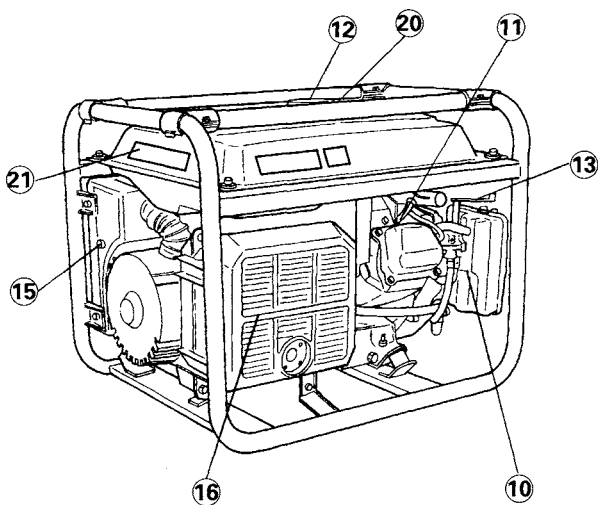

4. PRE-OPERATION CHECKS

1. CHECK ENGINE OIL

Before checking or refilling oil, be sure the generator is put on a stable and level surface with engine stopped.

■ Remove oil filter cap and check the engine oil level.

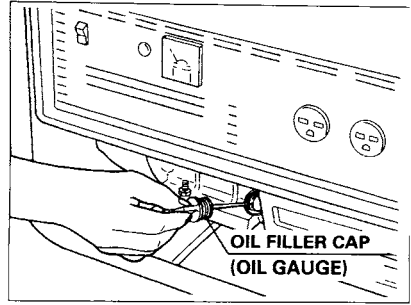

■ If oil level is below the lower level line, refill with suitable oil (see table below) to upper level line. Do not screw in the oil filler cap when checking oil level.

■ Change oil if contaminated. (See "How-To" Maintenance.)

■ Oil capacity

Model	Upper level
MGE1801 } MGE2901 }0.6 L
MGE4000 } MGE4800 } MGE5800 }1.2 L
MGE6700 }	

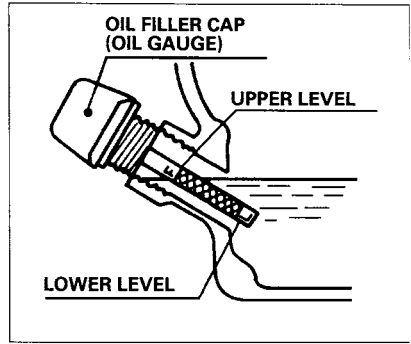

■ Recommended engine oil:

Use class SE (API classification) oil or a higher grade oil according to the table below. SAE 10W-30 or 10W-40 is recommended for general, all temperature use. If you prefer to use single grade oil, select the appropriate viscosity grade for the average temperature in your area.

Single grade	5W	10W	20W	# 20	#30	# 40	
		10W-30	10W-40				
Multigrade							
Ambient temperature	-20	-10	0	10	20	30	40°C
	-4	14	32	50	68	86	104°F

2. CHECK ENGINE FUEL.

WARNING

Do not refuel while smoking or near open flame or other such potential fire hazards. Otherwise fire accident may occur.

- Check fuel level at fuel gauge.
- If fuel level is low, refill with unleaded automotive gasoline.
- Be sure to use the fuel filter screen on the fuel filter neck.

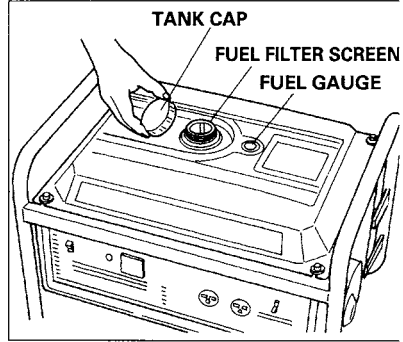

- Fuel tank capacity:

Model	Full
MGE1801	}14 L
MGE2901	
MGE4000	}21 L
MGE4800	
MGE5800	
MGE6700	

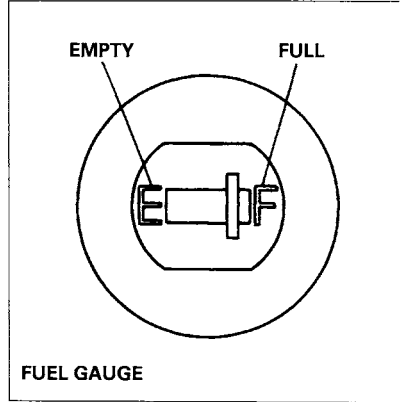

WARNING

Make sure you review each warning in order to prevent fire hazard.

- Do not refill tank while engine is running or hot.
- Close fuel cock before refueling with fuel.
- Be careful not to admit dust, dirt, water or other foreign objects into fuel.
- Wipe off spilt fuel thoroughly before starting engine.
- Keep open flames away.

3. CHECKING COMPONENTS

Check following items before starting engine:

- Fuel leakage from fuel hose, etc.
- Bolts and nuts for looseness.
- Components for damage or breakage.

4. CHECKING GENERATOR SURROUNDINGS.

WARNING

Make sure you review each warning in order to prevent fire hazard.

- **Keep area clear of inflammables or other hazardous materials.**
- **Keep generator at least 3 feet (1 meter) away from buildings or other structures.**
- **Only operate generator in a dry, well ventilated area.**
- **Keep exhaust pipe clear of foreign objects.**
- **Keep generator away from open flame.**
- **Keep generator on a stable and level surface.**
- **Do not block generator air vents with paper or other material.**

5. OPERATING PROCEDURES

1. STARTING THE ENGINE

(a) Set the engine switch to "RUN" position.

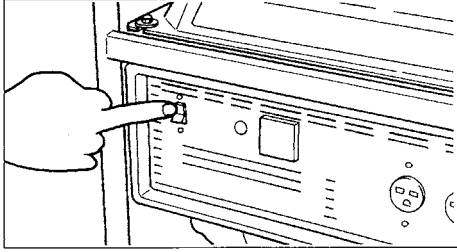

(b) Open the fuel cock.

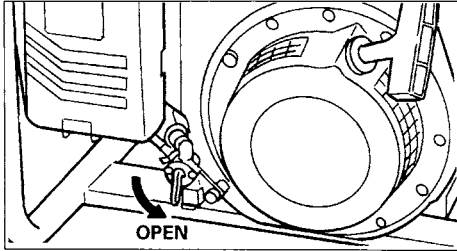

(c) Set the choke lever to "CLOSE" (arrow mark). Not necessary if the engine is warm.

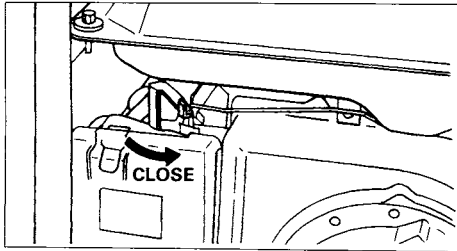

(d) Pull the starter handle slowly until resistance is felt.

This is the "Compression" point. Return the handle to its original position and pull swiftly.

■ Do not fully pull out the rope.

■ After starting, allow the starter handle to return to its original position while still holding the handle.

■ If the engine fails to start after several attempts, repeat above procedures with choke lever returned "OPEN" position.

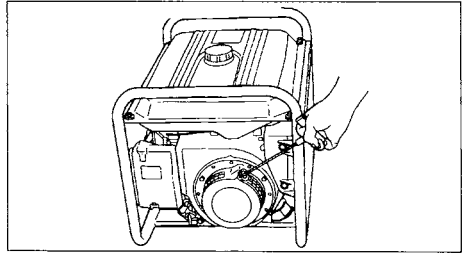

(e) After the engine started, return the choke lever gradually to "open" position.

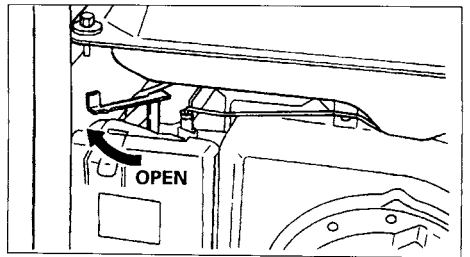

(f) Warm up the engine without a load for a few minutes.

2. USING ELECTRIC POWER

(1) AC APPLICATION

A	Single Voltage Type
----------	----------------------------

(a) Check the voltmeter or pilot lamp for proper voltage.

■ This generator is thoroughly tested and adjusted in the factory. If the generator does not produce the specified voltage, consult your nearest Mitsubishi Generator dealer.

(b) Turn off the switch(es) of the electrical appliance(s) before connecting to the generator.

(c) Insert the plug(s) of the electrical appliance(s) into the receptacle.

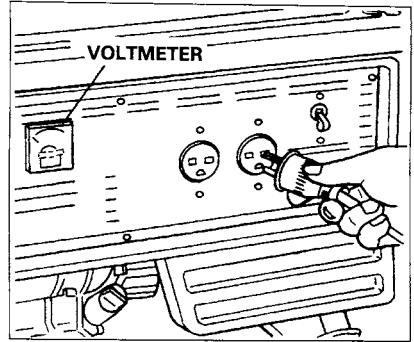

■ Check the amperage of the receptacles used referring to TABLE 1, and be sure not to take a current exceeding the specified amperage.

■ Be sure that the total wattage of all appliances does not exceed the rated output of the generator.

	<p>Up to total 15 ampere from two receptacles</p>
	<p>Up to 15 ampere</p>
	<p>Up to 20 ampere</p>
	<p>Up to 30 ampere</p>

TABLE 1

[CAUTION]

■ TABLE 1 does not apply to generators equipped with special receptacles.

⚠ WARNING

- To take out power from TWIST LOCK receptacle, insert the plug into receptacle and turn clockwise to lock it.
- Be sure to ground the generator if the connected electrical equipment is grounded.

NOTE:
 When the circuit breaker or no-fuse breaker turns off during operation, the generator is overloaded or the appliance is defective.
 Stop the generator immediately, check the appliance and/or generator for overloading or defect and repair as necessary.

- (d) Check the no-fuse breaker is "ON".
 If the breaker is "OFF", set the breaker "ON".
 Pilot lamp will illuminate.

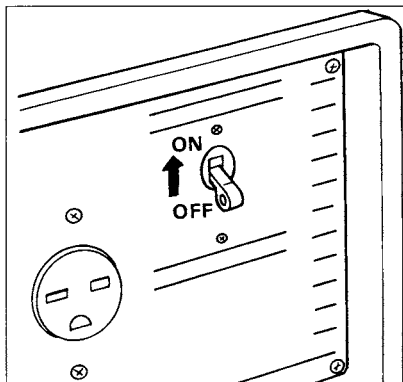

B Dual Voltage Type

- (a) Select the voltage using the FULL POWER SWITCH in accordance with the electrical appliance. Refer to TABLE 2.
 (b) Operate in the same way as step (a) through step (d) of single voltage type.

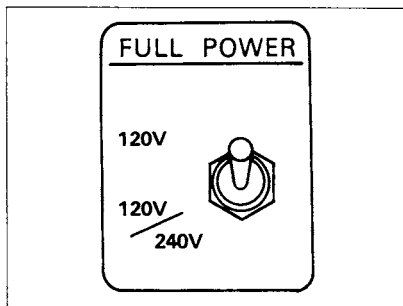

NOTE:
 Voltmeter always indicates the lower voltage whichever the FULL POWER SWITCH is set.

Switch	Lower Voltage Receptacle	Higher Voltage Receptacle
110V or 120V	rated output is available	unavailable
110V/220V or 120V/240V	half of rated output is available	rated output is available

TABLE 2

(2) DC APPLICATION (option)

This usage is applicable to 12V battery charging only.

(a) Charging instruction for battery

- Disconnect the leads for the battery.
- Make the battery fluid filler cap loose fully.
- Fill distilled water to the upper limit, if the battery fluid is low level.
- Measure the specific gravity for the battery fluid by using the hydrometer, and calculate the charging time in according with the table shown on right side.
- The specific gravity for the fully charged battery shall be within 1.26 to 1.28. It is recommended to confirm every one hour.

(b) Connect between the DC output terminals and the battery terminals using the charging leads.

- The leads shall be connected making sure of the (+) and (-) polarity.

(c) The DC circuit protector is to be set to "ON" after confirming the connection, if the protector is in "OFF" position.

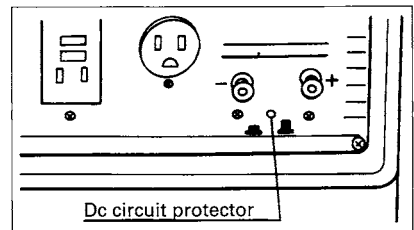
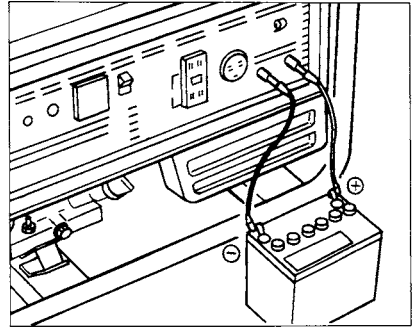
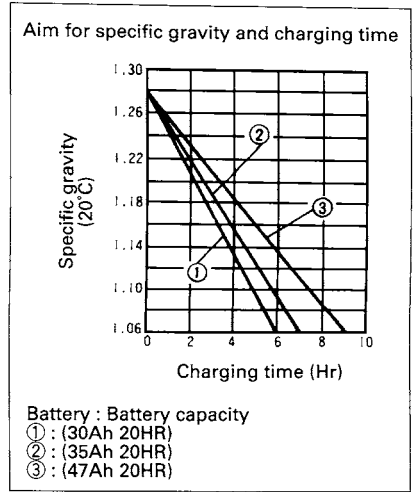

[CAUTION]

- The battery shall be handled in the well ventilated area avoiding fire or flammable material.
- Special attention shall be paid to the battery fluid not stuck to the eye or skin.
- The temperature of the battery fluid shall be maintained to 45°C or less, because of prevention for functional deterioration.

3. STOPPING THE GENERATOR

- (a) Turn off the power switch of the electric equipment or unplug the cord from receptacle of the generator.
- (b) Allow the engine about 3 minutes to cool down at no-load before stopping.

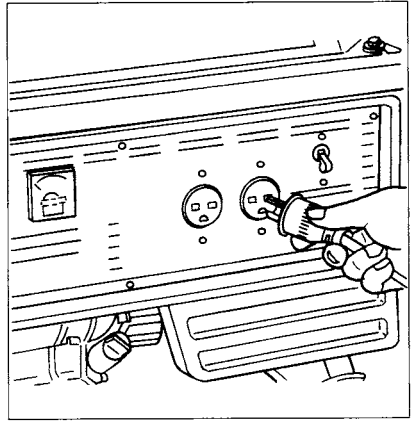

- (c) Set the engine stop switch to "STOP" position (OFF).

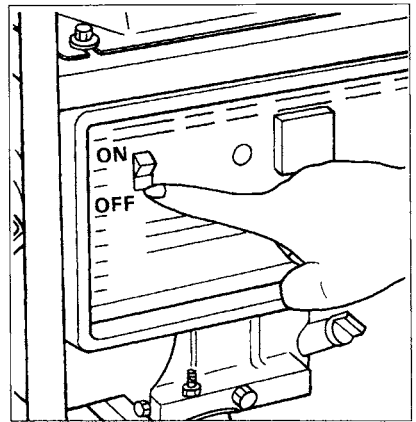

- (d) Close (stop) the fuel cock.

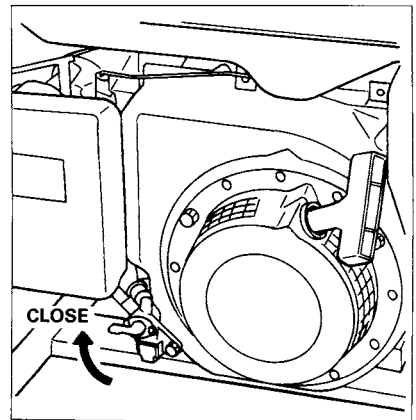

4. OIL SENSOR

- The oil sensor detects the fall in oil in the crankcase and automatically stops the engine when the oil level falls down below the safety limit.
- When engine has stopped automatically, check the oil level.
- If the engine does not start by usual starting procedures, check the oil level.
- Run

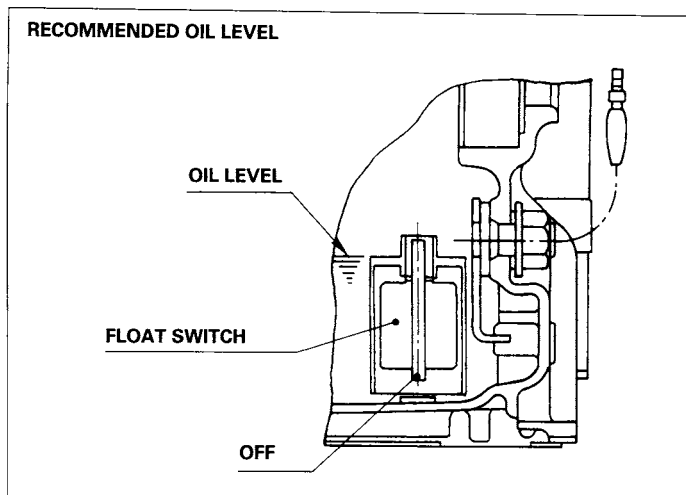

- Stop

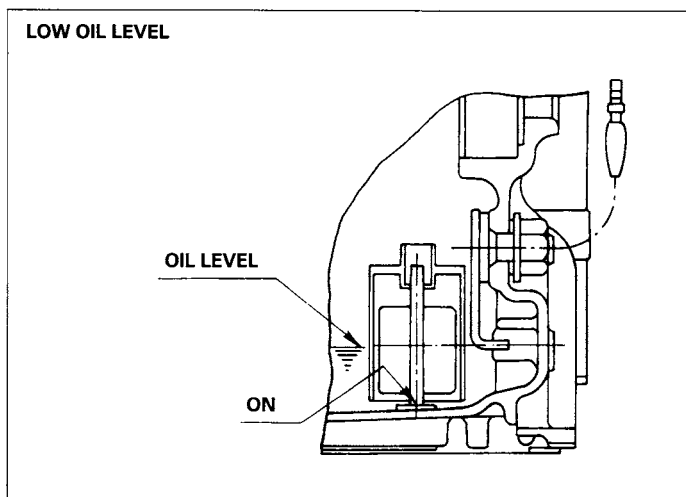

5. IDLE CONTROL (option)

IDLE CONTROL automatically reduces engine speed when load is OFF, and automatically increases engine speed up to rated r.p.m. when load is ON.

IDLE CONTROL provides fuel economy and low noise operation at no-load running.

(1) HOW TO USE IDLE CONTROL

- Start the engine with IDLE SWITCH off.

NOTE:

Warm up the engine without a load for a few minutes.

- Turn IDLE SWITCH on.

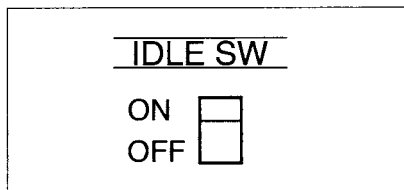

(2) CHECKING THE OPERATION

When IDLE CONTROL does not operate normally, please check followings:

- Overloaded?

Please make it sure that the generator is not overload.

NOTE:

Most induction loads such as electric motor require three to five times large wattage of their ratings at starting.

This starting wattage should not exceed the rated output of the generator.

- Turn the IDLE SWITCH off when the IDLE CONTROL does not work normally under the rated output.

(3) STOPPING THE ENGINE

- Turn off the switch of load or disconnect the load.

- Turn the IDLE SWITCH off.

- Set the engine stop switch to "STOP" position.

NOTE:

Allow the engine about 3 minutes to cool down at no-load before stopping.

6. SCOPE OF APPLICABILITY

It is recommended to use AC and DC power sources within the following scope.

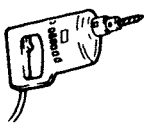
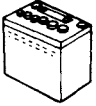
Applicable instruments	Model	Scope of applicability		Remarks	
		50Hz	60Hz		
Alternating current (AC) 	Light-Electric Heater Radio, Television	MGE1801	Up to 1,200W	Up to 1,500W	● The instruments which require much starting current and some kinds of motors may be unable to be used even if they are within the applicable scope.
		MGE2901	Up to 2,200W	Up to 2500W	
		MGE4000	Up to 2,800W	Up to 3,300W	
		MGE4800	Up to 3,300W	Up to 4,100W	
		MGE5800	Up to 4,200W	Up to 5,000W	
		MGE6700	Up to 5,100W	Up to 5,800W	
Motors with single phase 	Motors with single phase	MGE1801	Up to 400W	Up to 500W	● The circuit breaker turns OFF when the current exceeding the applicable scope is used or when the applied instrument is defective.
		MGE2901	Up to 700W	Up to 900W	
		MGE4000	Up to 900W	Up to 1,100W	
		MGE4800	Up to 1,100W	Up to 1,300W	
		MGE5800	Up to 1,400W	Up to 1,700W	
		MGE6700	Up to 1,700W	Up to 1,900W	
Direct current (DC) 		MGE1801 MGE2901 MGE4000 MGE4800 MGE5800 MGE6700	Up to 12V-8.3A		

7. MAINTENANCE SCHEDULE

Daily	<ul style="list-style-type: none"> ● Check the air cleaner ● Check oil level and refill to the upper level before starting the engine. ● Check all the points indicated in "PRE-OPERATION CHECKS".
50 hours (Weekly)	<ul style="list-style-type: none"> ● Clean and wash air-cleaner element. More often if used in dirty or dusty environments. ● Change engine oil. (The initial oil change must be conducted after the first 25 hours operation.) ● Check spark plug, and clean and adjust if necessary. ● Check and clean the fuel shut-off valve.
100 hours	<ul style="list-style-type: none"> ● Replace spark plug. ● Replace air-cleaner element. ○ Decarbonize cylinder head, valves and piston. ○ Check and replace carbon brushes.
3 years	<ul style="list-style-type: none"> ○ Inspect control panel components. ○ Check rotor and stator. ○ Replace engine mount rubber. ○ Overhaul engine. ● Change fuel lines.

NOTE:

Initial oil change should performed after first 25 hours of use. Thereafter change oil every 50 hours. Before changing oil, check for a suitable way to dispose of the old oil. Do not pour it down into sewage drains, onto garden soil or into open streams. Your local zoning environmental regulations will give you more detailed instructions on proper disposal.

Items marked with a ○ required advanced skill and tools, so they should be done by the distributor.

8. "HOW-TO" MAINTENANCE

1. ENGINE OIL CHANGE

Change engine oil every 50 hours.

(for a new engine, change oil after 25 hours.)

- (a) Drain oil by removing the drain plug and the oil filler cap while the engine is warm.
- (b) Reinstall the drain plug and fill the engine with oil until it reaches the upper level on the oil filler cap.

■ Use fresh and high quality lubricating oil to the specified quantity.

If contaminated or deteriorated oil is used or the quantity of the engine oil is not sufficient, the engine damage will result and its life will be greatly shortened.

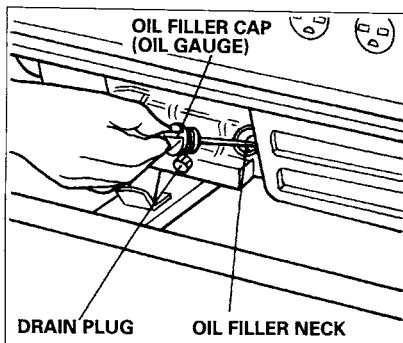

2. SERVICING THE AIR CLEANER

Maintaining an air cleaner in proper condition is very important. Dirt induced through improperly installed, improperly serviced, or inadequate elements damages and wears out engines.

Keep the element always clean.

- (a) Take out the air cleaner, clean it well in kerosene and dry it.
- (b) After wetting the element by clean engine oil, squeeze it tight by hand.
- (c) Lastly, put the element in the case and install it securely.

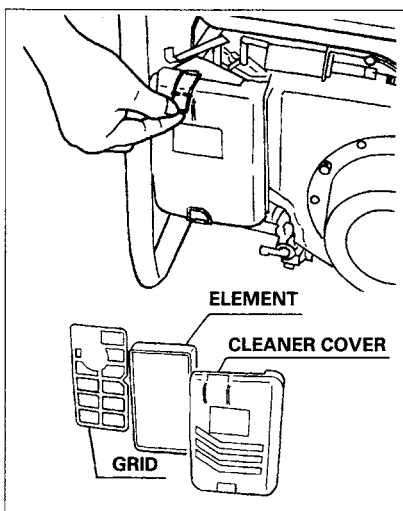
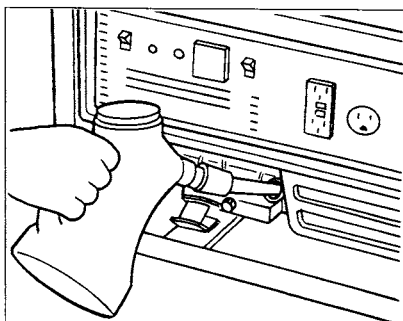

3. CLEANING AND ADJUSTING SPARK PLUG

- (a) If the plug is contaminated with carbon, remove it using a plug cleaner and wire brush.
- (b) Adjust the electrode gap to 0.7 to 0.8 mm (0.028" to 0.031").

SPARK PLUG

MGE1801, 2901: NGK BPR6HS

MGE4000, 4800, 5800, 6700

: NGK BPR5ES

4. CLEANING FUEL STRAINER

Dirt and water in the fuel are removed by the fuel strainer.

- (a) Remove the strainer cup and throw away water and dirt.
- (b) Clean the screen and strainer cup with gasoline.
- (c) Tightly fasten the cup to main body, making sure to avoid fuel leak.

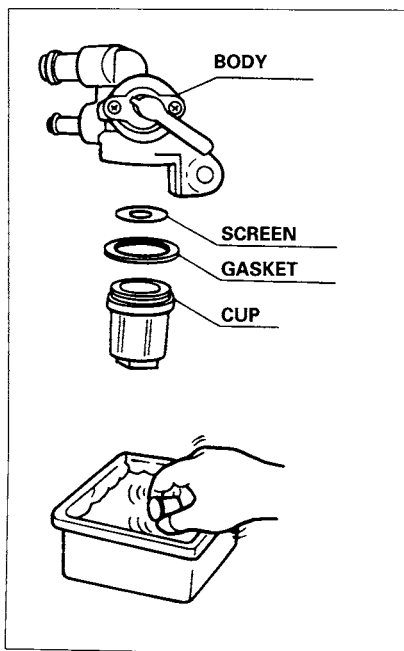
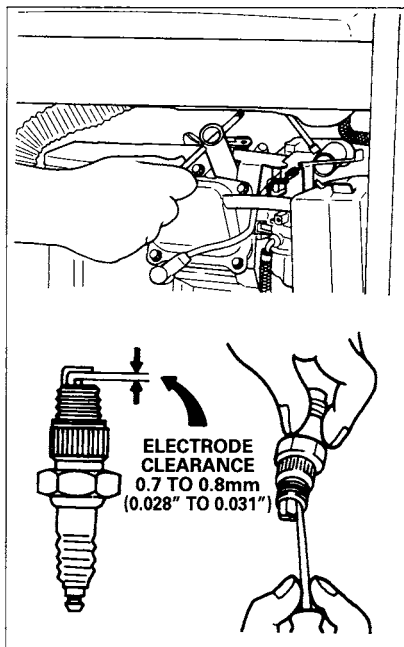

5. CHECKING CARBON BRUSH (Option)

Check the carbon brushes every 500 hours of operation.

- (1) Remove the brush cover from the generator.
- (2) Disconnect the wires from the brushes.
- (3) Loosen the two screws and remove the brush holder.
- (4) Remove the carbon brushes from the brush holder.
- (5) Check the length of the brushes. If the length is shorter than minimum 10 mm (0.4 in.), replace the brush with a new one.

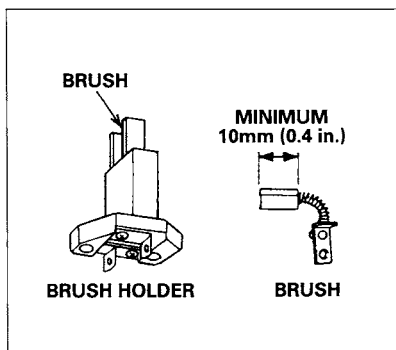
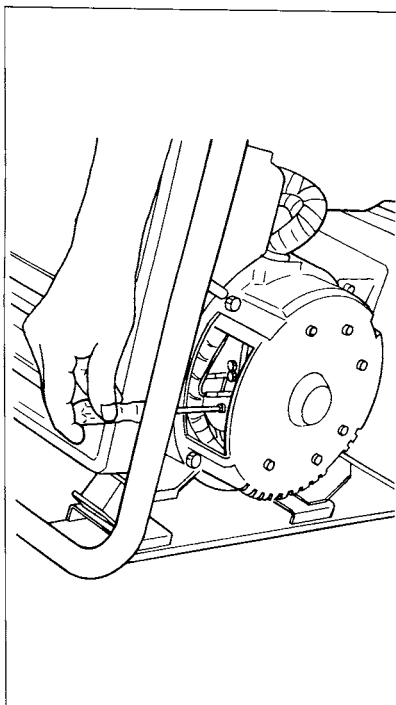

9. PREPARATION FOR STORAGE

The following procedures should be followed prior to storage of your generator for periods of 3 months or longer.

- Drain fuel from fuel tank carefully. Gasoline left in the fuel tank will eventually deteriorate making engine-starting difficult.
- Loosen the drain screw on the bottom of the carburetor float chamber, and drain the fuel completely.
- Change engine oil.
- Check for loose bolts and screws, tighten them if necessary.
- Clean generator thoroughly with oiled cloth. Spray with preservative if available.

NEVER USE WATER TO CLEAN GENERATOR!

- Pull starter handle until resistance is felt, leaving handle in that position.
- Store generator in a well ventilated, low humidity area.

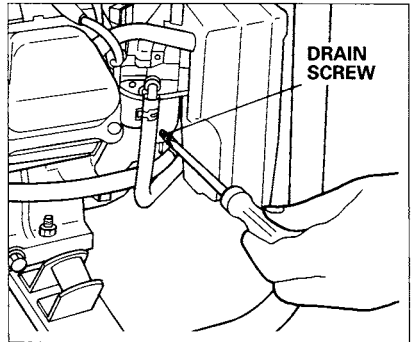

10. TROUBLE SHOOTING

When generator engine fails to start after several attempts, or if no electricity is available at the output socket, check the following chart.

If your generator still fails to start or generate electricity, contact your nearest Mitsubishi Generator dealer for further information or corrective procedures.

When Engine Fails to Start:

Check if choke lever is in its proper position.		Set the choke lever to "CLOSE" position.
Check if fuel cock is open.	↔	If closed, open fuel cock.
Check fuel level.		If empty, refill fuel tank making sure not to overfill.
Check to make sure generator is not connected to an appliance.		If connected, turn off the power switch on the connected appliance and unplug.
Check spark plug for loose spark plug cap.	↔	If loose, push spark plug cap back into place.
Check spark plug for contamination.		Remove spark plug and clean electrodes.

When No Electricity Is Generated at Receptacle:

Check to make sure no-fuse breaker is in the ON Position.	↔	After making sure that the total wattage of the electrical appliance is within permissible limits and there are no defects in the appliance, turn the circuit breaker to the "ON" position. If breaker, continue to actuate, consult your nearest servicing dealer.
Check AC and DC terminals for loose connections.		Secure connections if necessary.
Check to see if engine starting was attempted with appliances already connected to generator.	↔	Turn off switch on the appliance and disconnect cable from receptacle. Reconnect after generator has been started properly.

11. WIRING DIAGRAM

(1) Condenser Type (Standard)

MGE1801

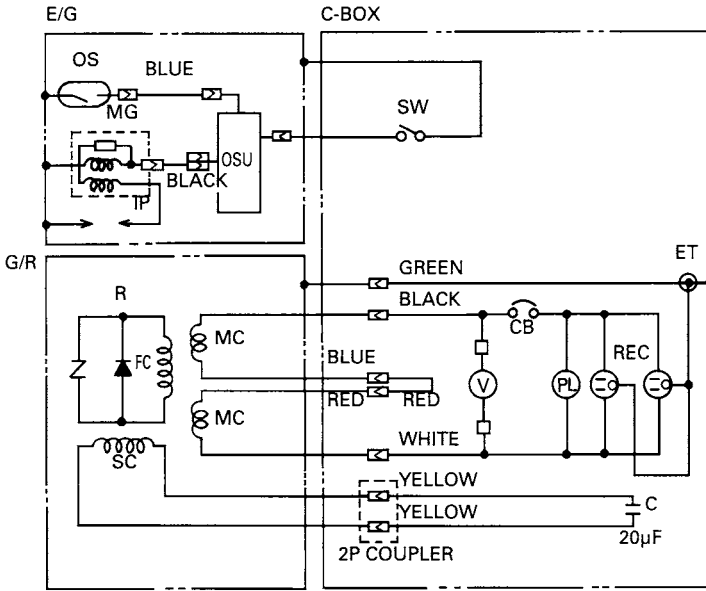

MGE2901

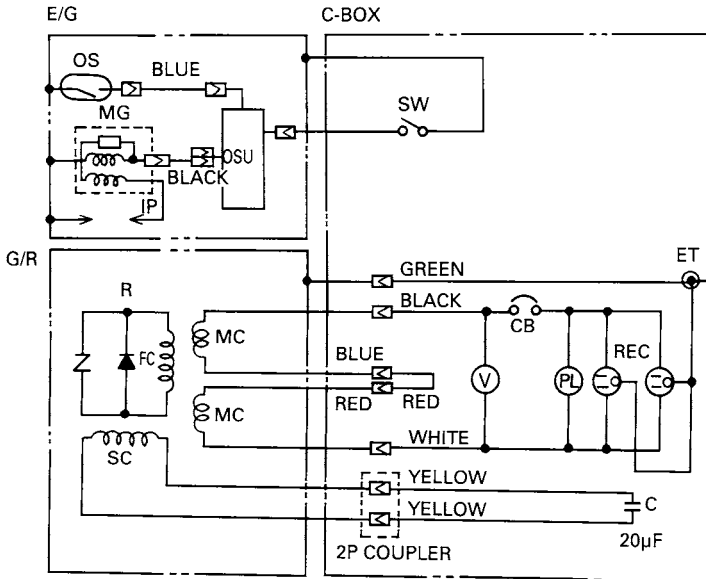

MGE4000, MGE4800

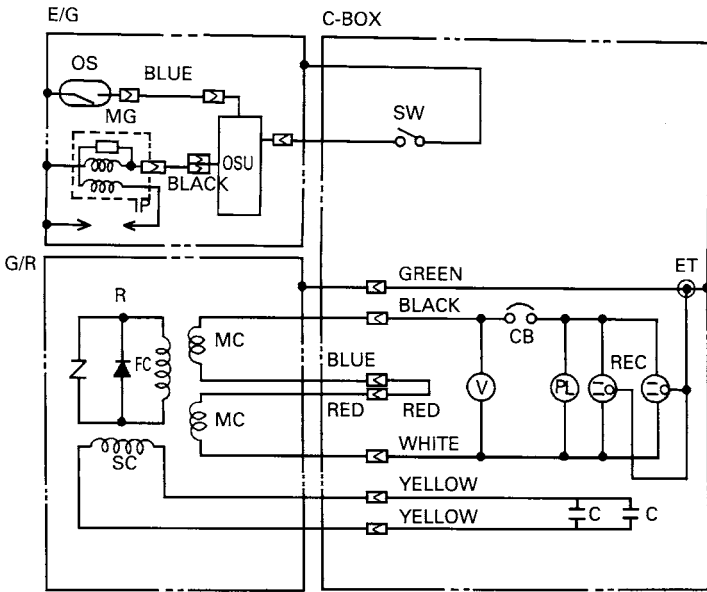

MGE5800, MGE6700

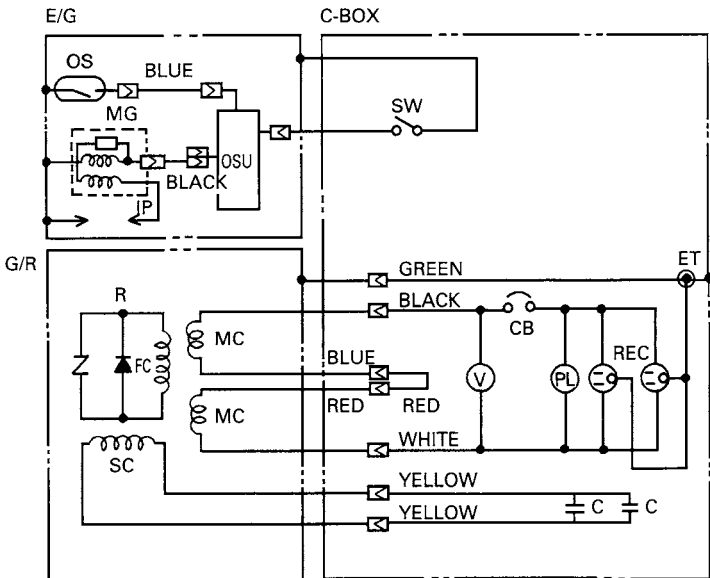

(2) Full Option
MGE1801

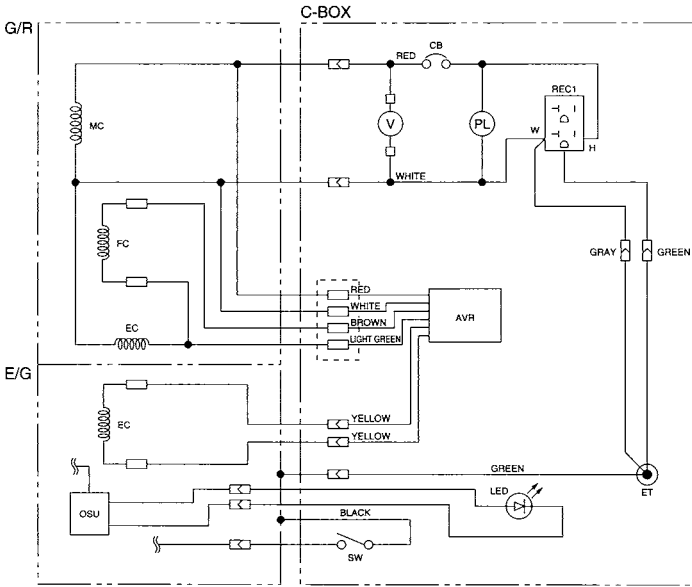

MGE2901

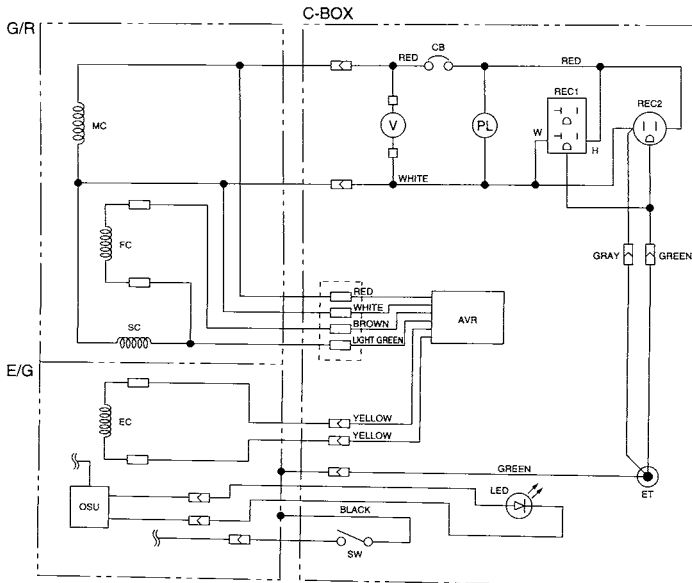

MGE4000

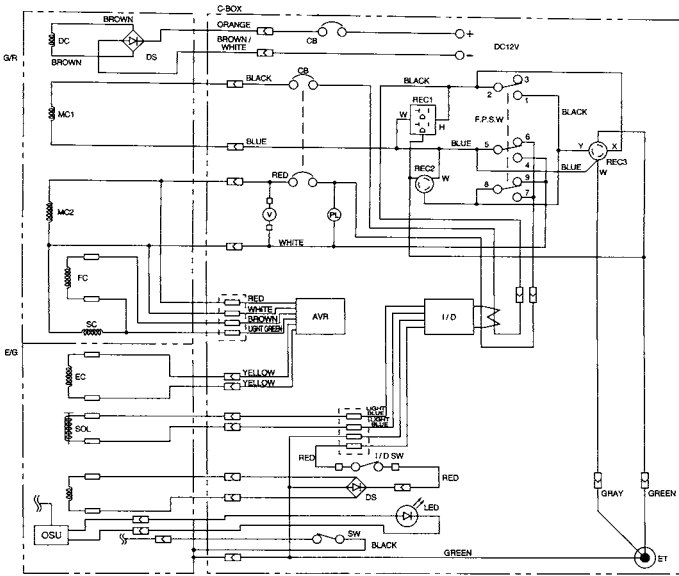

MGE4800~6700

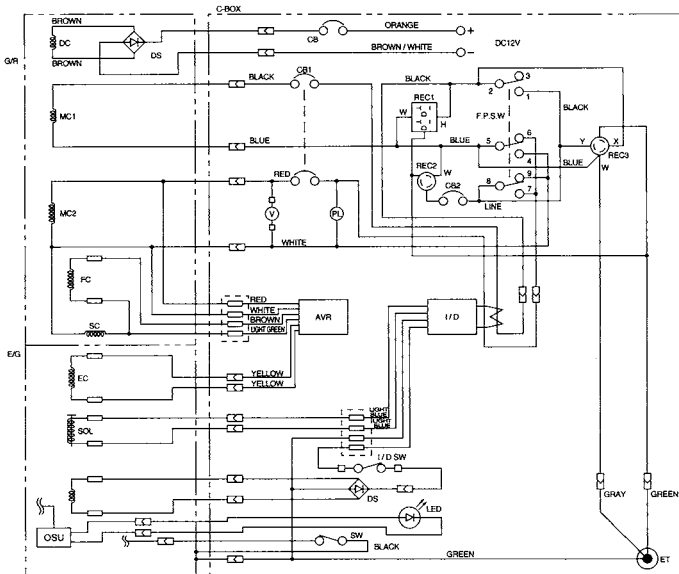

Symbol	Parts Name	Symbol	Parts Name	Symbol	Parts Name
E/G	Engine	R	Rotor CP	CB	Circuit breaker
G/R	Generator	OSU	Oil sensor unit	C	Capacitor
C-BOX	Control box	ET	Ground terminal	SW	Stop switch
MC	AC wiring	PL	Pilot lamp	MG	Fly wheel magneto
SC	Auxiliary winding	REC	AC receptacle		
FC	Field winding	V	Voltmeter		

Option

Symbol	Parts Name	Symbol	Parts Name	Symbol	Parts Name
DC	DC wiring	AVR	AVR unit	I/D	IDLE controler
EC	Exciter winding	F.P.SW	Full power switch	SOL	Solenoid valve
LED	Oil sensor lamp	DS	Diode stack		

12. OPTIONAL PARTS

1. HOW TO INSTALL THE BATTERY TRAY

Recommended battery:

Capacity: 12V/26A·h

[CAUTION]

- Clamp the wide of red sign to the positive (+) terminal and the black wire to the negative (-) terminal to the battery. Do not reserve these positions.
- Be sure the battery is installed on the battery mount tray securely.

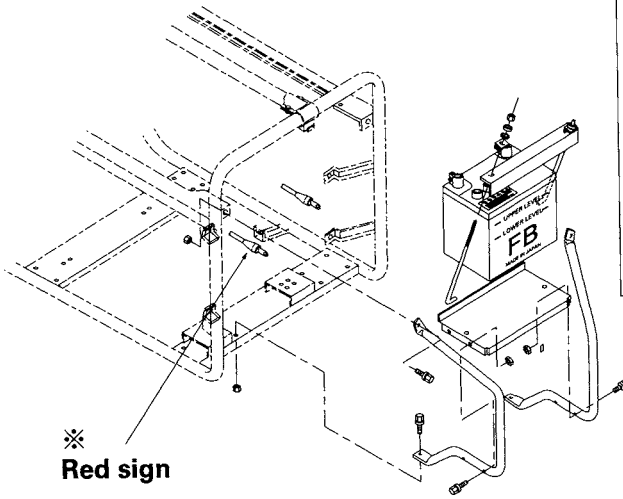

※
Red sign

2. WHEEL KIT INSTALLATION

