

Earthquake[®]

OPERATING INSTRUCTIONS & PARTS EXPLOSIONS FRONT TINE ROTOTILLERS

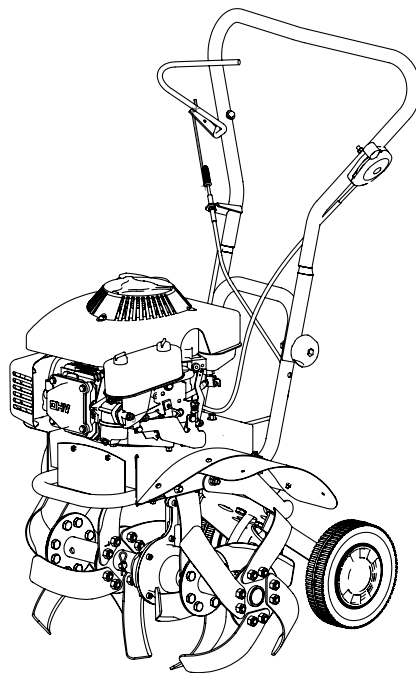

Model 3310V



GetEarthquake.com



OM3310V

Rev. 09/22/09

© 2009 Ardisam, Inc.
All Rights Reserved



INTRODUCTION

THANK YOU . . .

for purchasing an Earthquake® forward rotating front tine rototiller from Ardisam, Inc. We have worked to ensure that this front tine rototiller meets high standards for usability and durability. With proper care, your rototiller will provide many years of service. Please take the time to read this manual carefully to learn how to correctly operate and maintain your rototiller. This manual should be considered a permanent part of your rototiller. Due to continuous effort to perfect our product, certain procedures and specifications are subject to change without notice. Congratulations on your investment in quality.

CONTENTS

Registration	3
Safety	4
Unpacking and Assembly	7
Features	8
Controls	9
Operation.....	10
Maintenance & Storage	12
Troubleshooting & Repair	16
Notes	17
Parts Explosions.....	18

REGISTRATION

Record your model number and serial number in the space provided for easy reference. Fill out and mail the registration card located in your parts packet. Warranty is valid only if your completed registration card is received by Ardisam, Inc., within two weeks of the purchase date.

Model Number _____

Serial Number _____

Engine Serial Number _____

Date of Purchase _____

Place of Purchase _____



SAFETY

OWNER'S RESPONSIBILITY

Accurate assembly and safe and effective use of the rototiller is the owner's responsibility.

- Read and follow all safety instructions.
- Carefully follow all assembly instructions.
- Maintain the tiller according to directions and schedule included in this Earthquake operator's manual.
- Ensure that anyone who uses the tiller is familiar with all controls and safety precautions.

SPECIAL MESSAGES

Your manual contains special messages to bring attention to potential safety concerns, machine damage as well as helpful operating and servicing information. Please read all the information carefully to avoid injury and machine damage.

NOTE: General information is given throughout the manual that may help the operator in the operation or service of the machine.

IMPORTANT SAFETY PRECAUTIONS

Please read this section carefully. Operate the tiller according to the safety instructions and recommendations outlined here and inserted throughout the text. Anyone who uses this tiller must read the instructions and be familiar with the controls. Your tiller is equipped with a safety device that enables you to stop the tines quickly in an emergency. Learn how the drive safety control lever operates and how to control the tiller at all times.



This symbol points out important safety instructions which if not followed could endanger your personal safety. Read and follow all instructions in this manual before attempting to operate this equipment.

- Do not allow children to operate this rototiller. Keep small children away from the area being tilled. Do not allow adults to operate the tiller without proper instruction.

PREPARATION

- Dress appropriately when operating the tiller. Always wear sturdy footwear. Never wear sandals, sneakers, or open shoes, and never operate the tiller with bare feet. Do not wear loose clothing that might get caught in moving parts.
- Carefully inspect the area to be tilled and remove all foreign objects. Do not till above underground water lines, gas lines, electric cables, or pipes. Do not operate the tiller in soil with large rocks and foreign objects which can damage the equipment.
- Disengage all clutches and leave all control levers in the neutral position before starting the engine.
- Handle fuel with care; it is highly flammable.
 - a. Use an approved fuel container.
 - b. Never add fuel to a running engine or hot engine.

DANGER

DANGER INDICATES A SERIOUS INJURY OR FATALITY WILL RESULT IF THE SAFETY INSTRUCTIONS THAT FOLLOW THIS SIGNAL WORD ARE NOT OBEYED.

WARNING

WARNING INDICATES A SERIOUS INJURY OR FATALITY COULD RESULT IF THE SAFETY INSTRUCTIONS THAT FOLLOW THIS SIGNAL WORD ARE NOT OBEYED.

CAUTION

CAUTION INDICATES YOU CAN OR YOUR EQUIPMENT CAN BE HURT IF THE SAFETY INSTRUCTIONS THAT FOLLOW THIS SIGNAL WORD ARE NOT OBEYED.

IMPORTANT

IMPORTANT INDICATES HELPFUL INFORMATION FOR PROPER ASSEMBLY, OPERATION, OR MAINTENANCE OF YOUR EQUIPMENT.

WARNING

YOU MUST READ, UNDERSTAND AND COMPLY WITH ALL SAFETY AND OPERATING INSTRUCTIONS IN THIS MANUAL BEFORE ATTEMPTING TO SETUP AND OPERATE YOUR ROTOTILLER.

FAILURE TO COMPLY WITH ALL SAFETY AND OPERATING INSTRUCTIONS CAN RESULT IN LOSS OF MACHINE CONTROL, SERIOUS PERSONAL INJURY TO YOU AND/OR BYSTANDERS, AND RISK OF EQUIPMENT AND PROPERTY DAMAGE. THE TRIANGLE IN THE TEXT SIGNIFIES IMPORTANT CAUTIONS OR WARNINGS WHICH MUST BE FOLLOWED.

**CALIFORNIA PROPOSITION 65 WARNING
ENGINE EXHAUST FROM THIS PRODUCT CONTAINS CHEMICALS KNOWN TO THE STATE OF CALIFORNIA TO CAUSE CANCER, BIRTH DEFECTS, OR OTHER REPRODUCTIVE HARM.**

- c. Fill fuel tank outdoors with extreme care. Never fill fuel tank indoors.
- d. Replace gasoline cap securely and clean up spilled fuel before restarting.
- Never attempt to make any adjustments while the engine is running.

OPERATION

- Do not operate the tiller under the influence of alcohol or drugs.
- Never operate the tiller without guards, covers, and hoods in place.
- Keep hands, feet, and clothing away from rotating parts. Keep clear of tiller tines at all times.
- Tines rotate when tiller is engaged, tines rotate when the drive safety control lever is pulled down. Releasing the drive safety control lever to **neutral** stops the tines.
- Use extreme caution when operating on or crossing gravel drives, walks, or roads. Stay alert for hidden hazards or traffic.
- After striking a foreign object, stop the engine, remove the wire from the spark plug, thoroughly inspect the tiller for any damage, and repair the damage before restarting and operating the tiller.
- If vegetation clogs the tines, **STOP THE ENGINE AND DISCONNECT THE SPARK PLUG WIRE** before removing vegetation by hand.
- Engine muffler will be hot from operation. Do not touch it with bare skin or a severe burn may result.
- If the unit should start to vibrate abnormally, stop the engine and check immediately for the cause. Vibration is generally a warning of trouble.
- Do not run the engine indoors; exhaust fumes are deadly.
- Do not overload the machine capacity by attempting to till too deep at too fast a rate.
- Never allow bystanders near the unit.
- Never operate the tiller without good visibility or light.
- Be careful when tilling in hard ground. The tines may catch in the ground and propel the tiller forward. If this occurs, let go of the handlebars and do not restrain the machine.
- Take all possible precautions when leaving the machine unattended. Disengage all control levers, stop the engine, wait for all moving parts to stop, and make certain guards and shields are in place.
- When leaving the operating position for any reason:
 - shut off the engine.
 - wait for all moving parts to stop.

IMPORTANT

THE RIGHT AND LEFT SIDES OF YOUR ROTOTILLER ARE DETERMINED FROM THE OPERATING POSITION AS YOU FACE THE DIRECTION OF FORWARD TRAVEL.

ENGINE IS SHIPPED FROM FACTORY WITHOUT OIL. YOU MUST ADD ENGINE OIL BEFORE STARTING ENGINE.

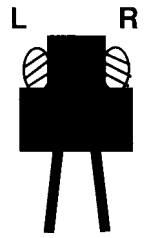

MAINTENANCE AND STORAGE

- Keep machine, attachments, and accessories in safe working condition.
- Check shear bolts and engine mounting bolts at frequent intervals for proper tightness to be sure the equipment is in safe working condition.
- To prevent accidental starting, always disconnect and secure the spark plug wire from the spark plug before performing tiller maintenance.
- Never run the engine indoors. Exhaust fumes are deadly.
- Always allow muffler to cool before filling fuel tank.
- Never store equipment with gasoline in the tank inside a closed building where fumes may reach an open flame or spark. Allow the engine to cool before storing in any building.
- Always refer to the operator's guide instructions for important details if the tiller is to be stored for an extended period.

SAFETY DECALS

This rototiller unit has been designed and manufactured to provide you with the safety and reliability you would expect from an industry leader in outdoor power equipment manufacturing.

Although reading this manual and the safety instructions it contains will provide you with the necessary basic knowledge to operate this equipment safely and effectively, we have placed several safety labels on the tiller to remind you of this important information while you are operating the unit.

These important safety labels are illustrated below, and are shown here to help familiarize you with the location and content of the safety messages you will see as you perform normal tilling operations. Please review these labels now. If you have any questions regarding their meaning or how to comply with these instructions, reread the complete safety instruction text on the preceding pages, or contact your local dealer.

Should any of the safety labels become unreadable because of being worn, faded, or otherwise damaged during the use of your tiller, please use the part number information provided to order a replacement label from your local authorized dealer.

The safety labels are easily applied, and will act as a constant visual reminder to you, and others who may use the equipment. Follow the safety instructions necessary for safe, effective operation of your rototiller.

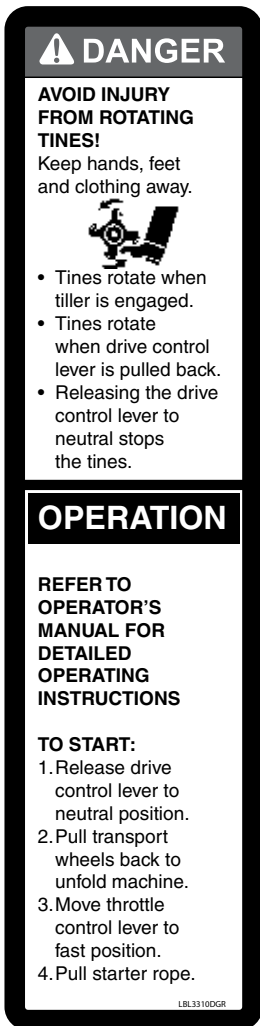

Part No. LBL3310DGR
TINES DANGER/OPERATION
Hood Decal

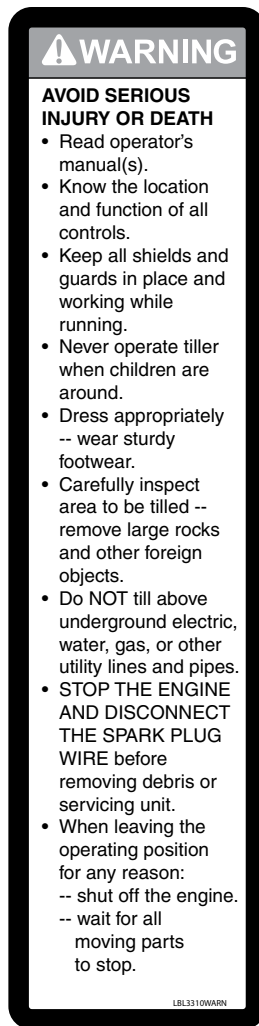

Part No. LBL3310WARN
WARNING
Pivot Mount Decal

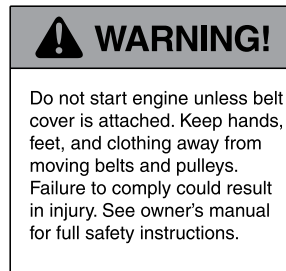

Part No. LBL3310PP
HOOD WARNING
Rear Hood Decal



Part No. LBL3100D
CLUTCH ENGAGE
Handlebar Decal

UNPACKING AND ASSEMBLY

UNPACK TILLER & ASSEMBLE

1. Open top of carton and remove handlebar assembly.
2. Parts bag for 3310V contains:
 - 2- M8 x 60 bolts
 - 2- hand knobs
 - 1- 10 x 50 clevis pins
 - 6- M5 x 12 bolts
 - 6- M5 nuts
 - 1-depth regulator lever
3. Cut open top of carton and remove machine:
 - a. Assemble top handlebar over lower loop. Put M8 x 60 bolts through both holes from inside out. Put on M8 spring washers and tighten with hand knobs. **SEE FIGURE 1.**
 - b. Assemble hood extensions using 6- M5 x 12 bolts plus 6- M5 nuts. **SEE FIGURE 2.**
 - c. Assemble tines to unit. Sharp edges of tines will be away from the operator at top or face down.
At front of machine. Use 2- M10 x 50 clevis pins plus 2- 2.5 x 51.25 hair pins. **SEE FIGURE 3.**
 - d. Install wheel assembly to machine using 2- M10 x 20 bolts with 2-M10 external toothed lock washers. **SEE FIGURE 4.**

INSTALL DEPTH REGULATOR LEVER

1. Install the depth regulator lever through hole in bracket from the bottom up with curve to rear of unit and secure with 4 x 94 hair pin. **SEE FIGURE 6 ON PAGE 9.**

FILL ENGINE CRANKCASE

1. Add oil according to engine manual. **Do not overfill.** Use a clean, high quality detergent oil. Container must be marked A.P.I. Service SF - SJ. Use no special additives with recommended oils. **Do not mix oil with gasoline.** Oil level must be full. Check the oil level by removing oil fill plug. Oil level should be up to the bottom of the fill plug opening.
2. Always check oil level before starting engine. Refer to engine manual for capacity and type of oil to use.

IMPORTANT

THE RIGHT AND LEFT SIDES OF YOUR ROTOTILLER ARE DETERMINED FROM THE OPERATING POSITION AS YOU FACE THE DIRECTION OF FORWARD TRAVEL.

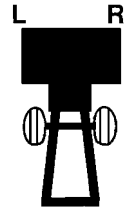

ENGINE IS SHIPPED FROM FACTORY WITHOUT OIL. YOU MUST ADD ENGINE OIL BEFORE STARTING ENGINE.

CAUTION

DO NOT TRY TO LIFT THE ROTOTILLER FROM THE CARTON.

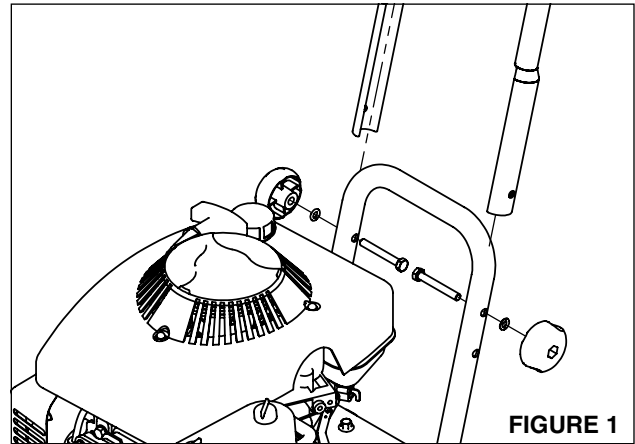

FIGURE 1

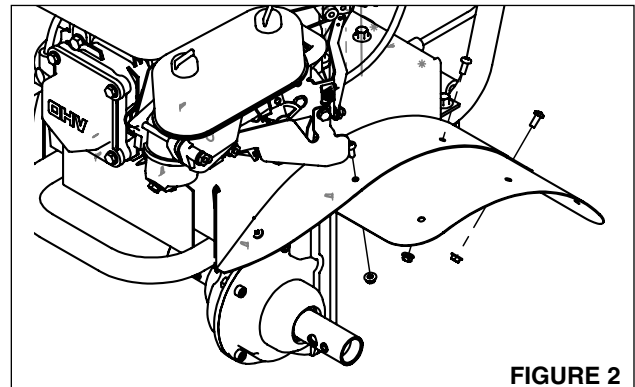

FIGURE 2

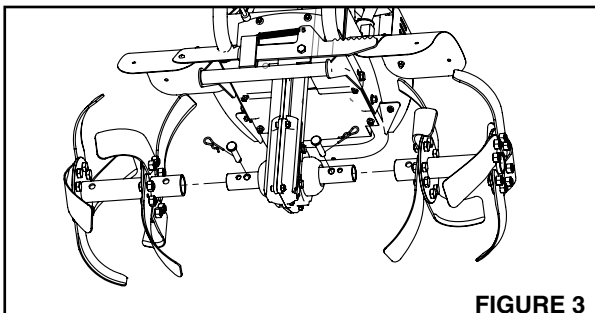

FIGURE 3

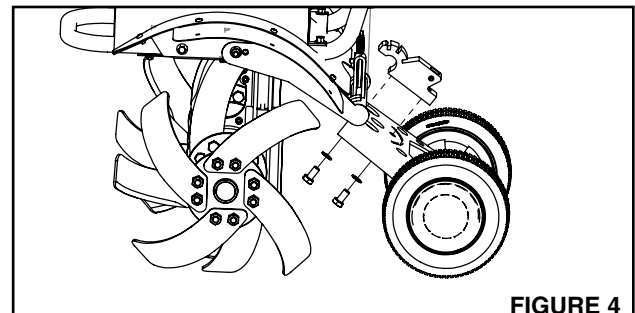
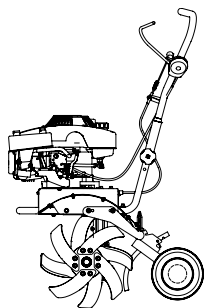
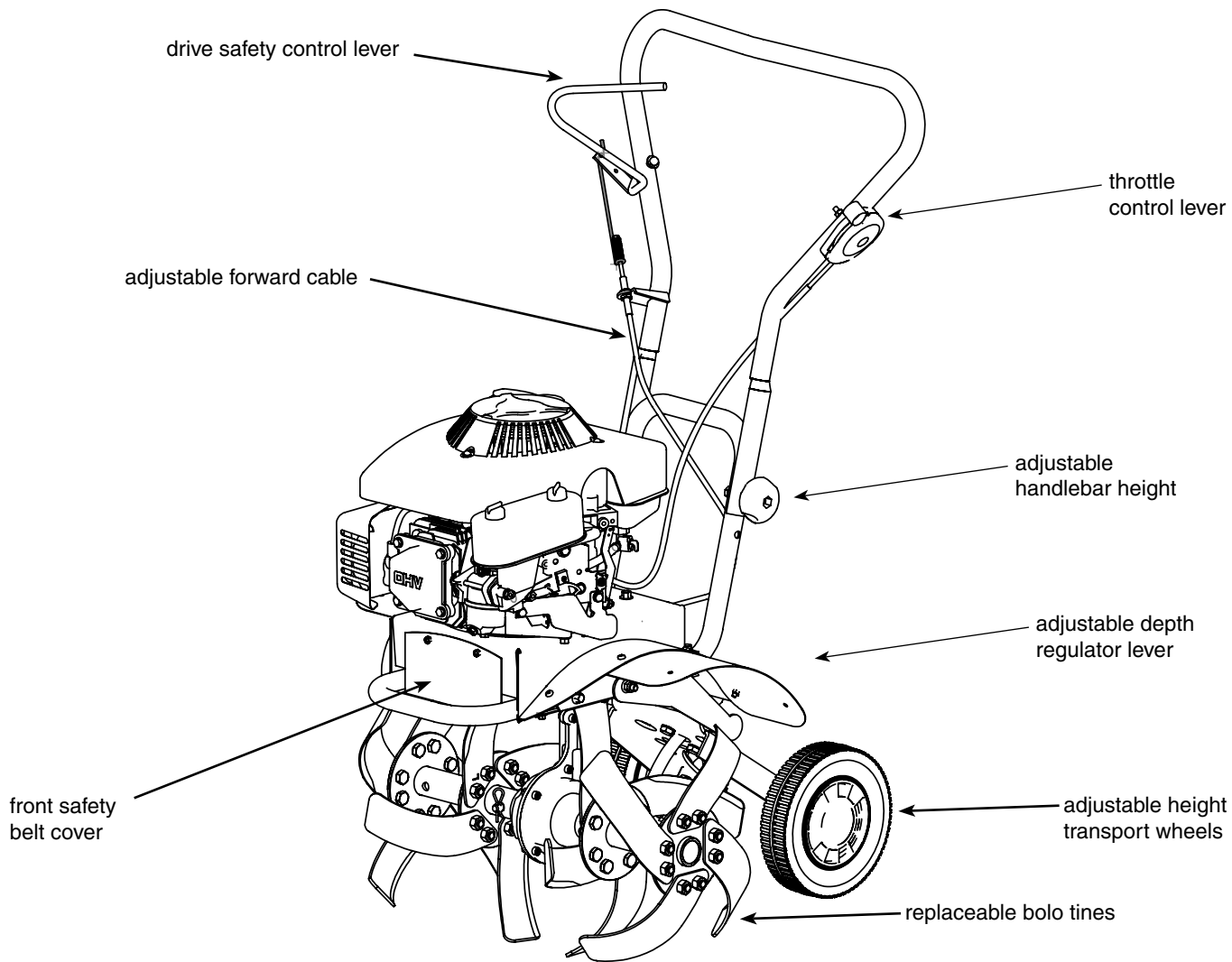
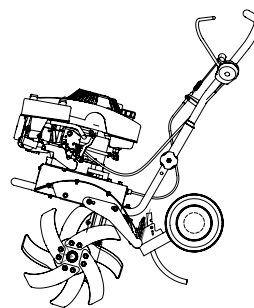

FIGURE 4

FEATURES (3310V)



Transport Position



Operating Position

CONTROLS

DRIVE SAFETY CONTROL LEVER

Engage tines into forward, releasing returns machine to neutral.

Pulling down on drive safety control lever engages the tines. Releasing the drive safety control lever disengages the tines to a neutral position.

BELT TENSION ADJUSTMENT

Proper belt tension is critical to good performance. After 1/2 hour of operation, all cables may have to be adjusted due to initial stretch. Thereafter, check tension after every 2 hours of operation.

To increase belt tension: SEE FIGURE 5.

1. Loosen upper jam nut. Turn nut up cable in 1/8" increments.
2. Tighten lower jam nut.
3. Check adjustment. Adjustment should not allow tines to direct drive when drive control lever is in neutral position.

This procedure can be repeated until conduit adjustment bolts have no more adjustment left. If no more adjustment can be made, belt may have to be replaced.

DEPTH REGULATOR LEVER

Tilling depth is controlled by the height of the depth regulator lever. SEE FIGURE 6.

To adjust tilling depth.

1. Remove hair pin.
2. Raise the depth regulator lever to position tines at chosen tilling depth.
3. Align hole in depth regulator lever with hole in depth regulator bracket and replace hair pin.

⚠ CAUTION

THIS INFORMATION IS PROVIDED HERE ONLY TO INTRODUCE THE CONTROLS. DO NOT START THE ENGINE AT THIS TIME. STARTING AND OPERATING INSTRUCTIONS ARE GIVEN ON PAGE 10. PLEASE READ THIS SECTION AND ALL OPERATING AND SAFETY INSTRUCTIONS BEFORE STARTING YOUR TILLER.

- AS A SAFETY PRECAUTION, THE DRIVE SAFETY CONTROL LEVER WILL NOT LOCK IN THE FORWARD POSITION.
- TO STOP THE TINES AT ANY TIME RELEASE THE DRIVE SAFETY CONTROL LEVER.

⚠ WARNING

ENGINE SHOULD BE OFF BEFORE ADJUSTING ANY CONTROLS.

DO NOT ADJUST TILLING DEPTH UNLESS DRIVE SAFETY CONTROL LEVER IS RELEASED TO THE NEUTRAL POSITION.

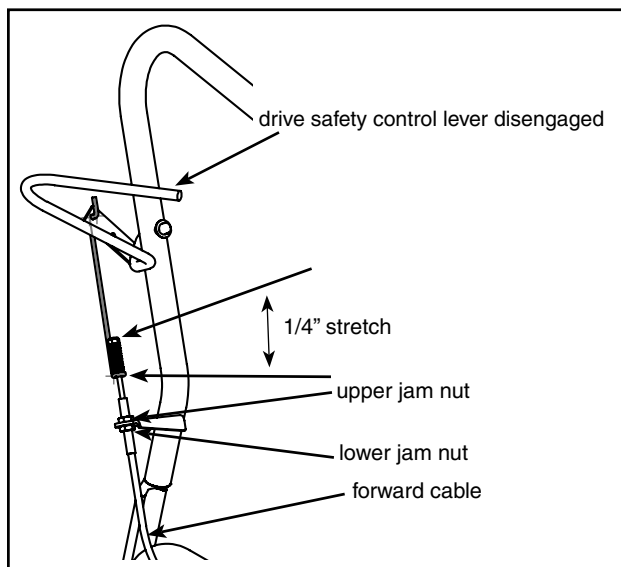
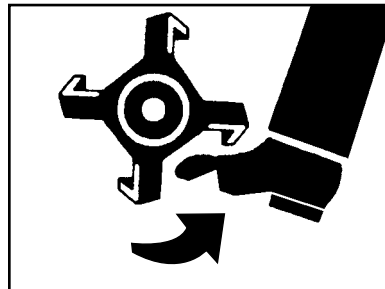

FIGURE 5-Model 3300V Handlebar

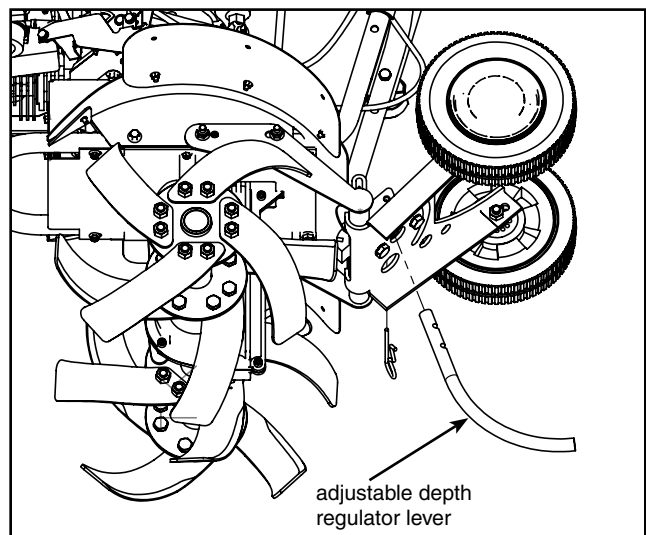

FIGURE 6-Depth Regulator Lever

OPERATION

PRE-START INSPECTION

1. Make sure all safety guards are in place and all nuts and bolts are secure.
2. Check oil level in engine crankcase. See your engine manual for procedure and specifications.
3. Inspect air cleaner for cleanliness. See your engine manual for procedure.
4. Check the fuel supply. Fill the fuel tank no closer than 1 inch from top of tank to provide space for expansion. See your engine manual for fuel recommendations.
5. Be sure spark plug wire is attached and spark plug is tightened securely.
6. Check position of wheels.
7. Check depth regulator lever position.
8. Examine underneath and around engine for signs of oil or fuel leaks.
9. Inspect fuel hoses for tightness and fuel seepage.
10. Look for signs of engine damage.
11. Remove excessive debris from muffler area and recoil starter.

START-UP

The controls required to start and run the rototiller are located on the handlebar.

A more detailed description of engine operation and all related precautions and procedures can be found in the engine manufacturer's manual that accompanies each tiller.

COLD STARTS

1. Move throttle lever to full choke position. **SEE FIGURE 7.**
2. Pull starting rope out slowly one time and allow to return normally.
3. Pull starting rope out rapidly, and allow rope to return normally.
4. When engine starts, gradually move choke lever to run position and increase throttle speed to "FAST" position.

RESTARTING A WARM ENGINE

Restarting an engine that is already warm from previous running does not normally require use of the choke.

1. Move throttle lever to run fast position.
2. Pull starting rope out rapidly until engine starts. Allow rope to return normally. Repeat until engine starts.

IMPORTANT

ENGINE IS SHIPPED FROM FACTORY WITHOUT OIL. YOU MUST ADD ENGINE OIL BEFORE STARTING ENGINE.

PRACTICE OPERATING THE CONTROLS AND TILLER WITH TINES OUT OF GROUND BEFORE BEGINNING TO TILL. IT IS IMPORTANT THAT YOU KNOW HOW TO USE THE TILLER PROPERLY, KEEP CONTROL AT ALL TIMES, STOP THE TINES AND WHEELS FROM TURNING, AND STOP THE ENGINE IF NECESSARY. IF YOU DO NOT KNOW HOW TO DO THESE THINGS, READ THE CONTROLS AND SAFETY SECTIONS BEFORE PROCEEDING.

CAUTION

PLEASE DO NOT START YOUR TILLER UNTIL YOU HAVE READ THE MANUAL THAT CAME WITH YOUR ENGINE, AND THE SECTIONS IN THIS MANUAL TITLED CONTROLS AND SAFETY. IF YOU HAVE READ THESE, FOLLOW THE STEPS BELOW TO START YOUR TILLER. ALWAYS PERFORM THIS PRE-START CHECKLIST BEFORE STARTING THE ENGINE.

WARNING

GASOLINE IS HIGHLY FLAMMABLE AND MUST BE HANDLED WITH CARE. NEVER FILL THE TANK WHEN THE ENGINE IS HOT OR RUNNING. ALWAYS MOVE OUTDOORS TO FILL THE TANK.

TEMPERATURE OF MUFFLER AND NEAR BY AREAS MAY EXCEED 150° F. AVOID THESE AREAS.

DO NOT MOVE CHOKE CONTROL TO CHOKE TO STOP ENGINE. BACKFIRE OR ENGINE DAMAGE MAY OCCUR.

TO STOP THE ENGINE AT ANY TIME, MOVE THROTTLE CONTROL TO THE OFF POSITION. TO STOP TINES AT ANY TIME, RELEASE DRIVE SAFETY CONTROL LEVER TO THE NEUTRAL POSITION.

ALWAYS RELEASE DRIVE SAFETY CONTROL LEVER TO THE NEUTRAL POSITION BEFORE ADJUSTING THE DEPTH OF THE REGULATOR LEVER.



FIGURE 7

OPERATING SPEED

For normal tilling, set the throttle lever to “fast”.

SHUTTING DOWN

To stop the engine at any time, move throttle control to the stop position. To stop tines at any time, release the drive safety control lever to the neutral position.

TILLING

1. Adjust the depth regulator lever to desired tilling depth.

NOTE: *Raise depth regulator lever up one hole at a time, testing tiller operation after each raise. Raising depth regulator lever too high can result in loss of control of tiller!*

2. Move the throttle control to **fast**.
3. Place the tiller in motion by pushing down on the drive safety control lever--this will engage the tines.

WARNING

EXTREME CAUTION MUST BE TAKEN IN SELECTING TILLING DEPTH. IF YOU ATTEMPT TO TILL TOO DEEPLY FOR SOIL CONDITIONS, THAT IS, WITH THE DRAG STAKE IN TOO HIGH A POSITION, LOSS OF CONTROL COULD RESULT.

IF REMOVING MATERIAL FROM THE TINES BY HAND, STOP ENGINE AND REMOVE SPARK PLUG WIRE FIRST.

DANGER

ENGINE AND SURROUNDING PARTS BECOME EXTREMELY HOT DURING NORMAL USE AND WILL CAUSE SERIOUS BURN INJURIES IF TOUCHED BEFORE THE ENGINE HAS COOLED.

ALLOW ENGINE TO COOL COMPLETELY BEFORE TOUCHING THESE HOT SURFACES.

ALWAYS KEEP HANDS AND FEET CLEAR OF ROTATING MACHINE PARTS.

MAINTENANCE AND STORAGE

MAINTENANCE SCHEDULE

Your rototiller has been designed and produced by the industry's leading manufacturer of outdoor power equipment to provide you with years of reliable operation.

Keeping your tiller in top running condition will prolong its life, and help you obtain optimum performance.

Please read this normal care schedule, and note the recommended care operating intervals to extend the life of your unit.

Maintenance Operation	Page	Before Each Use	50 hours or Every Season
Change belt tension	13	X	
Change forward belt	13		X
Engine maintenance	14	X	X
Check or fill engine crankcase	14	X	2
Clean tine axle shaft	14	X	
Lubrication	14		X
Check throttle control adjustment	-		1

EM = See engine manual

1 Adjust throttle control after first 3 hours of operation or if engine is hard to start or run-on occurs.

2 Change oil after first 5-8 hours of use, then after every 50 hours or every season. Change oil every 25 hours when operating under heavy load or in high temperatures.

SERVICING THE ROTOTILLER

The following information will help you make the necessary checks and perform the procedures required to follow the normal care recommendations made for your rototiller unit.

If you prefer, your local authorized dealer can make these checks and perform the required procedures for you.

⚠ WARNING

To prevent accidental starting:

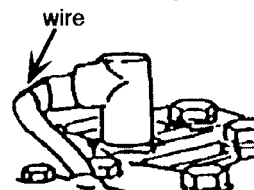

Engine must be turned off and cool, and spark plug wire must be removed and secured from spark plug before checking and adjusting engine or equipment.

CHECK BELT TENSION

Belt tension may decrease over time. It must be adjusted within the first half hour of operation, and checked after every two hours of operation. Proper adjustment will assure long belt life. Too much or too little belt tension will cause premature belt failure. To check and adjust the forward belt tension:

1. Turn off engine. Engine must be cool.
2. Remove spark plug wire from spark plug and secure.
3. With drive safety control lever in the neutral position, measure length of spring when in its relaxed state.
4. Pull down on drive safety control lever and measure length of spring when compressed. Ideal length would be 1/4" shorter. **SEE FIGURE 5.**

CHANGE FORWARD BELT

1. Turn off engine. Engine must be cool.
2. Remove spark plug wire from spark plug and secure.
3. Remove front and rear belt guards. **SEE FIGURE 8.**
 - remove the belt from the engine pulley:
 - gently pull the engine recoil rope to rotate the pulley.
 - with the pulley turning, force the belt out of the groove.
 - slide the belt free of the engine pulley.
 - pull the belt down and out of the way.
 - push the belt forward and out front of machine.
 - install new belt:
 - place belt in transmission pulley groove.
 - gently pull the engine recoil rope to rotate the pulley

WARNING

CHECK FORWARD BELT TENSION REGULARLY. TOO MUCH OR TOO LITTLE TENSION WILL CAUSE PREMATURE BELT FAILURE.

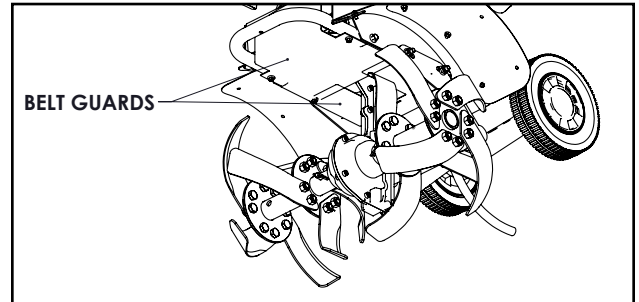

FIGURE 8-Belt Tension Adjustment

ENGINE MAINTENANCE

Refer to the engine manual included in your parts packet for information on engine maintenance. Your engine manual provides detailed information and a maintenance schedule for performing the following tasks:

1. Check oil level before each use or after every 8 hours of operation.
2. Change oil after first 5-8 hours of operation. Change oil while engine is warm. Refill with new oil of recommended grade.
4. Check spark plug yearly or every 100 hours of operation.
5. Service air cleaner.
6. Keep engine and parts clean.
7. Check engine and equipment often for loose nuts and bolts, keep these items tightened.

CHECK OR FILL ENGINE CRANKCASE

1. Add oil according to engine manual. **Do not overfill.** Use a clean, high quality detergent oil. Container must be marked A.P.I. Service SF - SJ. Use no special additives with recommended oils. **Do not mix oil with gasoline.** Oil level must be full. Check the oil level by removing oil fill plug. Oil level should be up to the bottom of the fill plug opening on most engines.
2. Always check oil level before starting engine. Refer to engine manual for capacity and type of oil to use.

CLEAN TINE AXLE SHAFT

1. Turn off engine. Engine must be cool.
2. Remove spark plug wire and secure from spark plug.
3. Remove all vegetation, string, wire, and other material that may have accumulated on the axle between the inside set of tines and the seal on the transmission housing.
4. Replace spark plug wire.

LUBRICATION

Proper lubrication of moving mechanical parts is critical for proper care and maintenance. Oil the moving parts using a 30 weight oil.

CHECK TILLER TRANSMISSION GREASE

NOTE: Tiller transmission is shipped from factory with the proper amount of grease. (Suggested grease ML365)

To add grease, remove both high and low grease ports. Inject grease in bottom until you see some at the top hole, transmission is now full. **SEE FIGURE 9.**

IMPORTANT

ENGINE IS SHIPPED FROM FACTORY WITHOUT OIL. YOU MUST ADD ENGINE OIL BEFORE STARTING ENGINE.

ENGINE CAN OVERHEAT AND BECOME DAMAGED IF DEBRIS BLOCKS THE COOLING SYSTEM OR ROTATING SCREEN.

NEVER RUN ENGINE WITHOUT COMPLETE AIR CLEANER INSTALLED ON ENGINE.

CAUTION

DO NOT OPERATE TILLER BEFORE READING THE ENGINE MANUAL PROVIDED IN THE PARTS PACKET.

WARNING

TEMPERATURE OF MUFFLER AND NEAR BY AREAS MAY EXCEED 150° F. AVOID THESE AREAS.

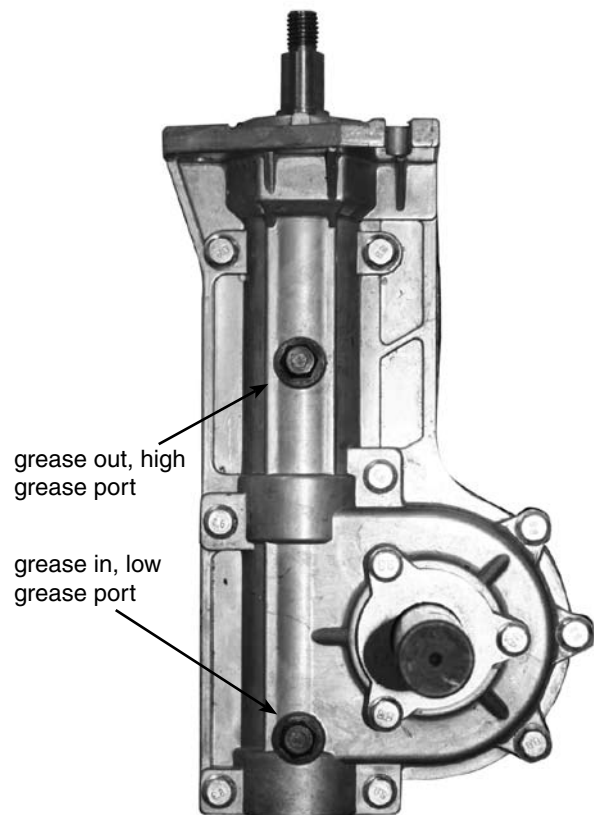

FIGURE 9

STORAGE

PREPARE FOR STORAGE

Follow the steps below to prepare your tiller for storage. Read your engine manual for detailed instructions on preparing the engine for storage.

1. Protect wheels and axles from rust:
 - Coat the axles lightly with axle grease.
2. Drain fuel system completely following engine manufacturer's instructions or add fuel stabilizer to prevent fuel from gumming up during extended storage period.
3. While engine is still warm, drain the oil from the engine. Refill with fresh oil of the recommended grade.
4. Clean external surfaces, engine and cooling fan.
5. Remove spark plug, pour one ounce of SAE 30 oil into spark plug hole.
6. Plug hole and pull starter cord slowly to distribute oil evenly in cylinder head area.
7. Reinstall spark plug.
8. Transport unit to a suitable storage location. If you have chosen to use a fuel stabilizer and have not drained the fuel system, follow all safety instructions storage precautions in this manual to prevent the possibility of fire from the ignition of gasoline fumes. Remember, gasoline fumes can travel to distant sources of ignition and ignite, causing risk of explosion and fire.
9. If there is any possibility of unauthorized use or tampering, remove the spark plug and store it in a safe place before storing the rototiller unit. Be sure to plug the spark plug hole to prevent foreign material from entering.

WARNING

DO NOT STORE TILLER IN AN UNVENTILATED AREA WHERE FUEL FUMES MAY REACH FLAME, SPARKS, PILOT LIGHTS OR AN IGNITED OBJECT. DRAIN FUEL OUTDOORS AWAY FROM ANY IGNITION SOURCES. USE ONLY APPROVED FUEL CONTAINERS.

TROUBLESHOOTING AND REPAIR

TROUBLESHOOTING GUIDE

While normal care and routine maintenance will extend the life of your rototiller, prolonged or constant use may eventually require that service be performed to allow it to continue operating properly. The troubleshooting guide below lists the most common problems, causes and remedies.

WARNING

PRACTICE SAFETY AT ALL TIMES. ENGINE MUST BE TURNED OFF AND ALLOWED TO COOL, AND SPARK PLUG WIRE MUST BE DISCONNECTED AND SECURED BEFORE ATTEMPTING ANY MAINTENANCE OR REPAIR.

FAILURE TO COMPLY WITH THIS SAFETY REQUIREMENT CAN RESULT IN SERIOUS PERSONAL INJURY TO YOU OR BYSTANDERS.

PROBLEM	REMEDY/ACTION
Engine will not start	<ul style="list-style-type: none"> • Add gas to gas tank. • Connect spark plug wire to spark plug • Throttle must be positioned at choke for a cold start
Engine runs rough, floods during operation	<ul style="list-style-type: none"> • Clean or replace air cleaner
Engine is hard to start	<ul style="list-style-type: none"> • Drain old fuel and replace with fresh. Use gas stabilizer at end of season • Make sure spark plug wire is securely attached to spark plug • Drive safety control lever must be released to neutral to start the engine
Engine misses or lacks power	<ul style="list-style-type: none"> • Raise the tines for shallow tilling by raising the depth regulator lever • Clean or replace air cleaner • Improper carburetor adjustment, take to authorized engine service center • Replace spark plug and adjust gap • Drain and refill gas tank and carburetor
Engine will not stop when throttle control is positioned at stop	<ul style="list-style-type: none"> • See engine manual to check and adjust throttle linkage
Tiller moves forward during starting	<ul style="list-style-type: none"> • Drive safety control lever must be released to neutral to start the engine
Tiller is difficult to control when tilling (machine jumps or lurches forward)	<ul style="list-style-type: none"> • Lower engine speed in hard ground • Raise the tines for shallower tilling by lowering the depth regulator lever
Belts squeal in forward operation	<ul style="list-style-type: none"> • Turn engine off and allow muffler to cool • Disconnect spark plug wire and secure from spark plug • Release drive safety control lever to neutral • Adjust engage cable • Replace spark plug wire
Excessive heat build up in transmission/tine area during tilling	<ul style="list-style-type: none"> • Remove vegetation • Check transmission fluid and fill if needed

3310V HANDLEBAR PARTS

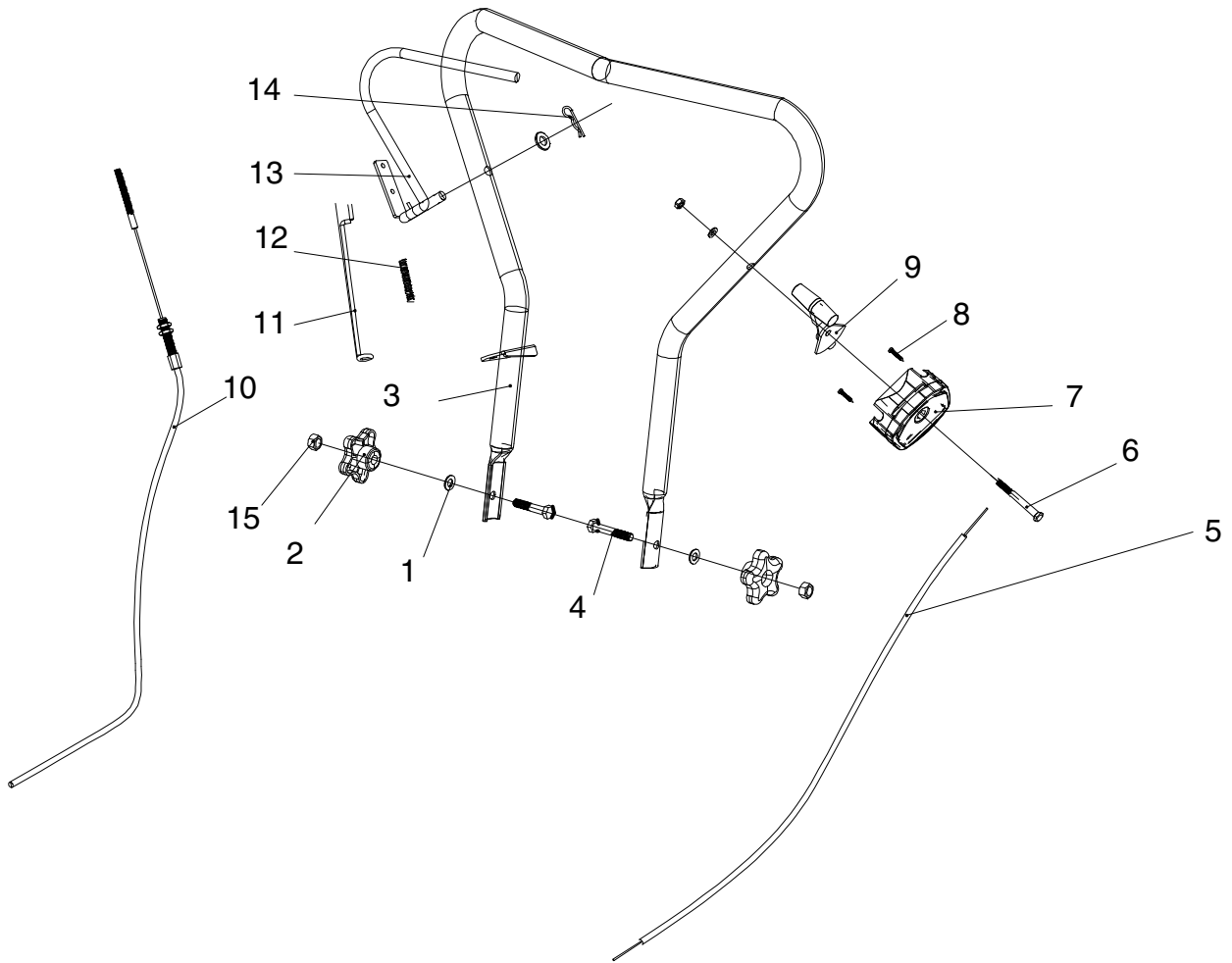

REF. NO.	PART #	DESCRIPTION	QTY.
1	331066	OUTER HEX FLANGE BOLT M8X18	2
2	331047	HANDLE KNOB	2
3	331046	HANDLE ASSEMBLY	1
4	331099	SCREW, M8X45	2
5	331088	THROTTLE CABLE ASSEMBLY	1
6	331059	OUTER HEXAGON BOLT M6X60	1
7	331090	THROTTLE SWITCH BOX	1

REF. NO.	PART #	DESCRIPTION	QTY.
8	331075	SCREW M3X20	2
9	331089	THROTTLE HANDLEBAR ASSEMBLY	1
10	331018	CLUTCH CABLE ASSEMBLY	1
11	331020	CLUTCH LEVER	1
12	331081	SPRING	1
13	331019	CLUTCH HANDLEBAR ASSEMBLY	1
14	331005	B PIN, 2X37	1
15	331054	LOCKNUT M8	2

3310V MOTOR MOUNT & HOOD PARTS

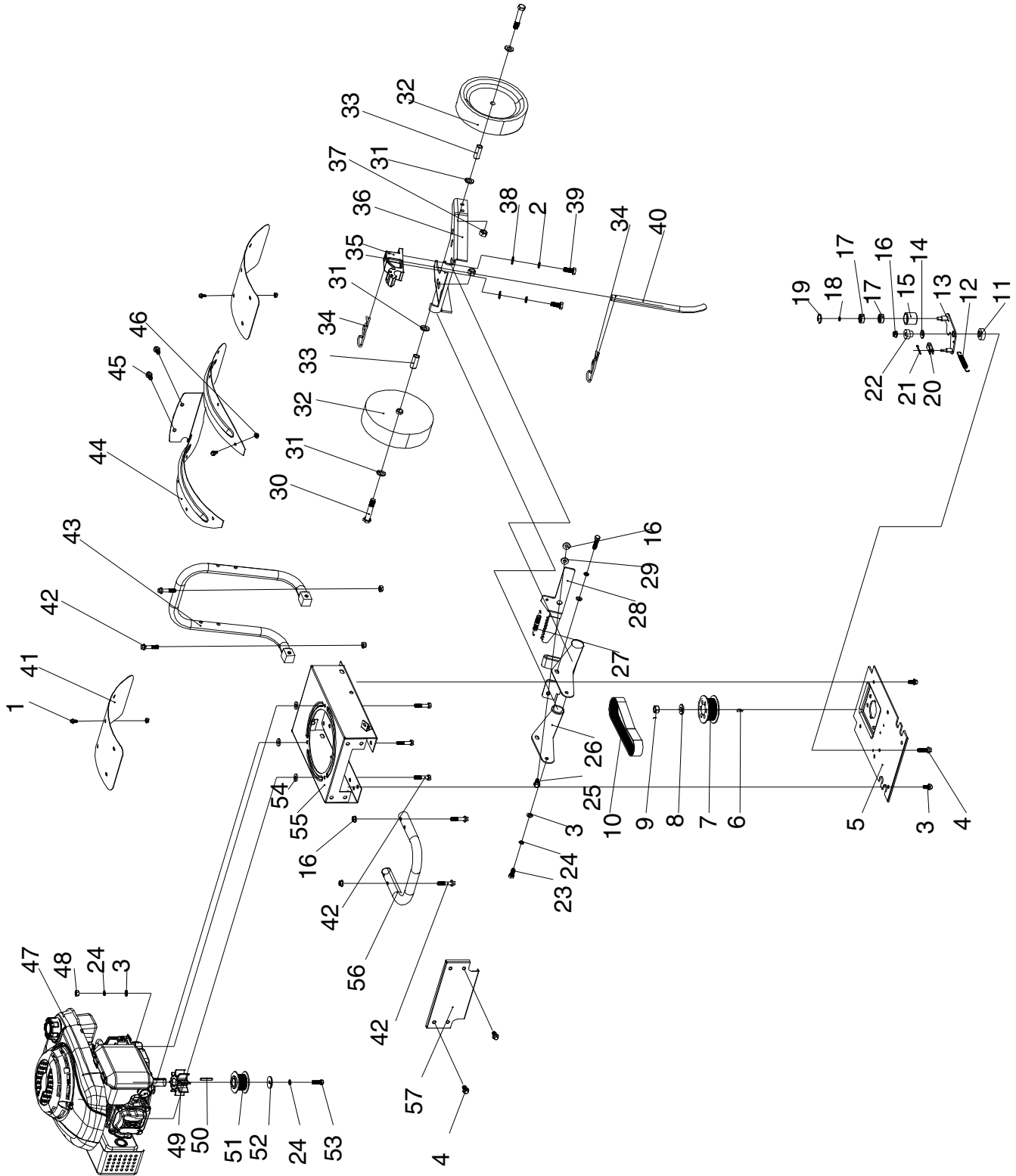

3310V MOTOR MOUNT & HOOD PARTS

REF. NO.	PART #	DESCRIPTION	QTY.
1	331062	OUTER HEX FLANGE BOLT M6X12	12
2	331083	SPRING WASHER 10	34
3	331066	OUTER HEX FLANGE BOLT M8X18	10
4	331069	OUTER HEX FLANGE BOLT M8X50	1
5	331027	ENGINE SEAT ASSEMBLY	1
6	331077	SEMICIRC KEY 4X6.5X16	1
7	331010	BIG BELT WHEEL	1
8	331037	FLAT WASHER 12X28X3	1
9	331052	LOCKNUT M12	1
10	331008	BELT 10PD457	1
11	331086	TENSION SHAFT BUSHING	1
12	331026	DRAFT SPRING	1
13	331017	CLUTCH ARM ASSEMBLY	1
14	331041	FLAT WASHER 8X22X2	1
15	331087	TENSION WHEEL	1
16	331054	LOCKNUT M8	8
17	331024	DEEP GROOVE BALL BEARING 628	2
18	331016	CIRCLIP 8	1
19	331014	CIRCLIP 24	1
20	331013	CABLE CLIP	1
21	331091	UNCORK PIN	1
22	331009	BELT BLOCK BUSHING	1
23	331060	OUTER HEX BOLT M8X20	2
24	331084	SPRING WASHER 8	12
25	331067	OUTER HEX FLANGE BOLT M8X22	1
26	331032	FIXED SEAT	1
27	331026	DRAFT SPRING	1
28	331001	ADJUSTABLE PLATE	1
29	331003	ADJUSTABLE SHAFT BUSHING	1

REF. NO.	PART #	DESCRIPTION	QTY.
30	331094	WHEEL BOLT	2
31	331036	FLAT WASHER 10X22X2	4
32	331093	WHEEL	2
33	331096	WHEEL SHAFT BUSHING	2
34	331007	B PIN 4X95	2
35	331002	ADJUSTABLE SEAT	1
36	331095	WHEEL SEAT	1
37	331051	LOCKNUT M10	2
38	331035	FLAT WASHER 10	2
39	331058	OUTER HEX BOLT M10X25	2
40	331025	DEPTH REGULATOR	1
41	331029	EXTENDED PLATE	2
42	331068	OUTER HEX FLANGE BOLT M8X40	9
43	331045	HANDLE ARM ASSEMBLY	1
44	331031	FENDER	1
45	331065	OUTER HEX FLANGE BOLT M8X16	2
46	331033	FLANGE LOCKNUT	8
47	31321	GASOLINE ENGINE	1
48	331070	OUTER HEX NUT M8	3
49	331030	FAN	1
50	331034	FLAT KEY	1
51	331080	SMALL BELT WHEEL	1
52	331040	FLAT WASHER 8X32X3	1
53	331012	BOLT, HEX 3/8X1	1
54	331048	HEAT INSULATION PLATE	3
55	331028	ENGINE SEAT COVER ASSEMBLY	1
56	331085	STEEL HANDLE	1
57	331043	FRONT COVER BOARD	1

TINE & TRANSMISSION PARTS

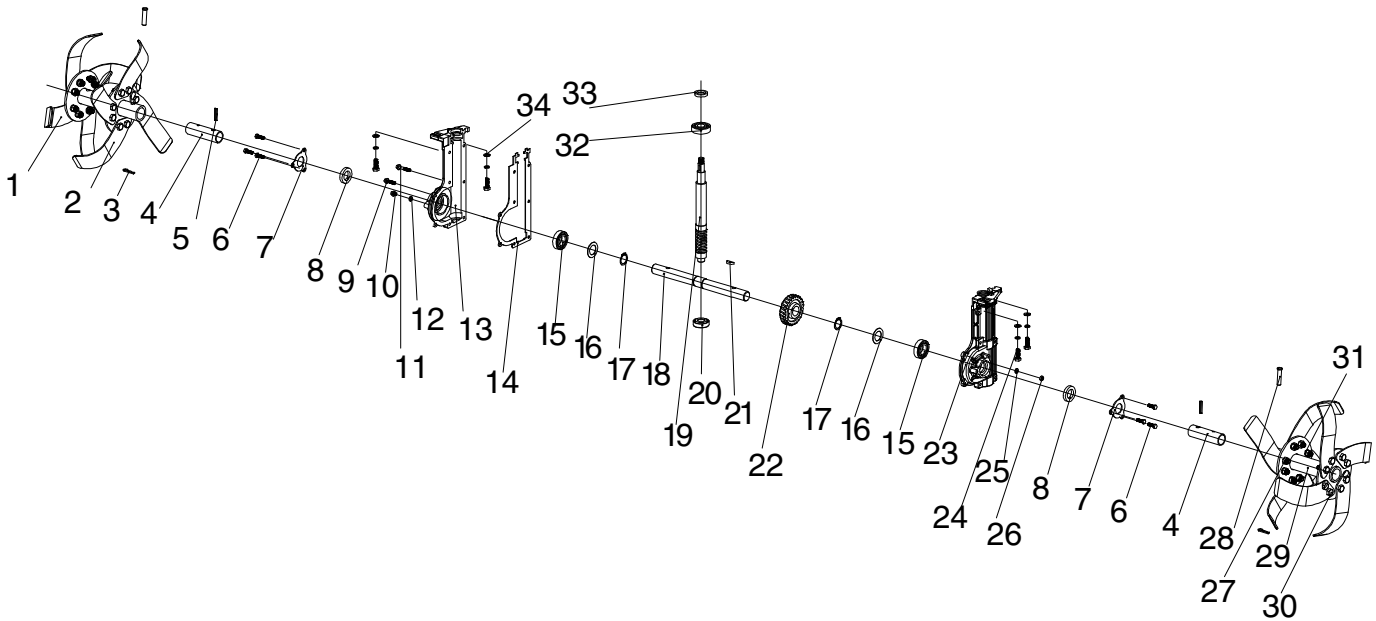

REF. NO.	PART #	DESCRIPTION	QTY.
1	331049	LEFT BLADE	8
2	331073	RIGHT BLADE	8
3	311006	B PIN 2X46	2
4	311072	OUTPUT SHAFT BUSHING	2
5	331082	SPRING PIN 6X30	2
6	331062	OUTER HEX FLANGE BOLT M6X12	12
7	331055	OIL SEAL CAP	2
8	331042	FRAMEWORK OIL SEAL 25X40X7	2
9	331063	OUTER HEX FLANGE BOLT M6X25	5
10	3310100	OUTER HEX FLANGE BOLT M10X1X14	2
11	331064	OUTER HEX FLANGE BOLT M6X35	4
12	331092	WASHER ASSEMBLY 10	2
13	331050	LEFT CASE	1
14	331044	GASKET	1
15	331022	DEEP GROOVE BALL BEARING 6005	2
16	331004	ADJUSTABLE WASHER	2
17	331015	CIRCLIP 25	2

REF. NO.	PART #	DESCRIPTION	QTY.
18	331071	OUTPUT SHAFT	1
19	331097	WORM	1
20	331021	CONE NEEDLE BEARING 30203	1
21	331078	SEMICIRCULAR KEY 5X9X22	2
22	331098	WORM WHEEL	1
23	331074	RIGHT CASE	1
24	331061	OUTER HEXAGON BOLT M8X25	4
25	331038	FLAT WASHER 6	9
26	331053	LOCKNUT M6	9
27	331056	OUTER HEXAGON BOLT M10X1	32
28	331079	SHAFT PIN 10X45	2
29	331011	BLADE SHAFT ASSEMBLY	2
30	331057	OUTER HEX BOLT M10X1X25	32
31	331083	SPRING WASHER 10	34
32	331023	DEEP GROOVE BALL BEARING 6204	1
33	331042	FRAMEWORK OIL SEAL 20X32X6	1
34	331039	FLAT WASHER 8	21

Earthquake®

FRONT TINE ROTOTILLERS

1-YEAR LIMITED WARRANTY

Terms and Conditions

Ardisam, Inc., a manufacturing company, warrants this **EARTHQUAKE® FRONT TINE ROTOTILLER** to be free from defects in the material or workmanship for a period of one year from the date of purchase. During the one year warranty of this product, Ardisam will furnish 100% parts and labor to correct any defect caused by faulty material or workmanship. Items subject to normal wear and tear, such as belts, batteries, tines, shear bolts and tires, due to the nature of their function are not covered under this warranty. Any unit used in a commercial application is covered for a period of 90 days after purchase. The engine is covered under a separate warranty issued by the engine manufacturer as stated in the engine manual.

If warranty work needs to be done, contact your place of purchase or Ardisam, Inc. for an authorized service center in your area. Ardisam will make the necessary repairs if a service center is not available. **To obtain warranty service and/or replacement instructions, you must have prior approval from Ardisam before shipping your package to us by calling our customer service department at 800-345-6007 for a return material authorization number (RMA#).** All items must be shipped prepaid. Ardisam, Inc. will at no charge, repair or replace, at their discretion, any defective part which falls under the conditions stated above.

Ardisam retains the right to change models, specifications and price without notice. This product if used as intended, will give you years of trouble free service. We hope you will enjoy the quality of our products for years to come.

For replacement parts, phone 800-345-6007 or go online to www.GetEarthquake.com.

This warranty applies to the original owner with a proof of purchase and is not transferable. It supersedes all other warranties either expressed or implied and all other obligations to liabilities on our part. Ardisam, Inc. does not assume, and does not authorize any other person to assume for us, any liability in connection with the sale of our products.

The warranty applies only to products which have not been subjected to negligent use, misuse, alteration, accident or repairs made by anyone not certified by Ardisam, Inc. This guarantee is void unless the warranty card is properly filled out and received by Ardisam, Inc., within 30 days of purchase or go to www.GetEarthquake.com for online registration.



EARTHQUAKE
A Division of Ardisam, Inc.
1160 Eighth Avenue; P.O. Box 666
Cumberland, Wisconsin 54829
800-345-6007 · Fax (715) 822-4180
E-mail: info@ardisam.com



Visit www.ardisam.com and discover more innovations that will benefit you throughout the year.



Earthquake, Division of Ardisam, Inc.
1160 Eighth Avenue; P.O. Box 666
Cumberland, Wisconsin 54829
800-345-6007 · Fax (715) 822-4180
E-mail: info@ardisam.com



GetEarthquake.com